

Dit document wordt u aangeboden door:

# KEMAR

technische groothandel

Kemar - Technische Groothandel  
Rijnsburgerweg 50c  
2341AB Oegstgeest

Telefoon: 071 565 1177  
Fax: 071 528 3663

E-mail: [info@kemar.nl](mailto:info@kemar.nl)  
Website: [www.kemar.nl](http://www.kemar.nl)

[online aanvraagformulier](#)

# INDEX

TCT Planer Knives . . . . .	3
HSS Planer Knives . . . . .	4
HSS Corrugated Knives . . . . .	5
TCT Corrugated Knives . . . . .	5
Inch Dimension Saws . . . . .	6-7
Saw Blades . . . . .	6-44
Snip Saws / Insert Trimmers for Edgebanders . . . . .	33-35
Saw Blade Hogging Units . . . . .	45-49
TCT / Insert Groovers . . . . .	50-54
Insert Cutterheads . . . . .	55-66
Planer Cutterheads . . . . .	57,59 & 67
Corrugated Cutterheads . . . . .	67
Standard Inserts / Inserts for Edgebanders . . . . .	68-72
Blank Inserts for Multi Profile Cutterheads . . . . .	73
Ball Bearing / Guide Rings / Spacers / Bushings . . . . .	74-75
Quick Change Chucks / Reducing Chucks . . . . .	76-77
Drill / Boring Bits . . . . .	78-86
Special Production Boring Bits . . . . .	87
TCT Countersinks . . . . .	87
Slot Mortise Bits . . . . .	88
Insert Trimming Router Bits . . . . .	89-90
Special Insert Tooling . . . . .	90
Recommended Cutting Angles . . . . .	91

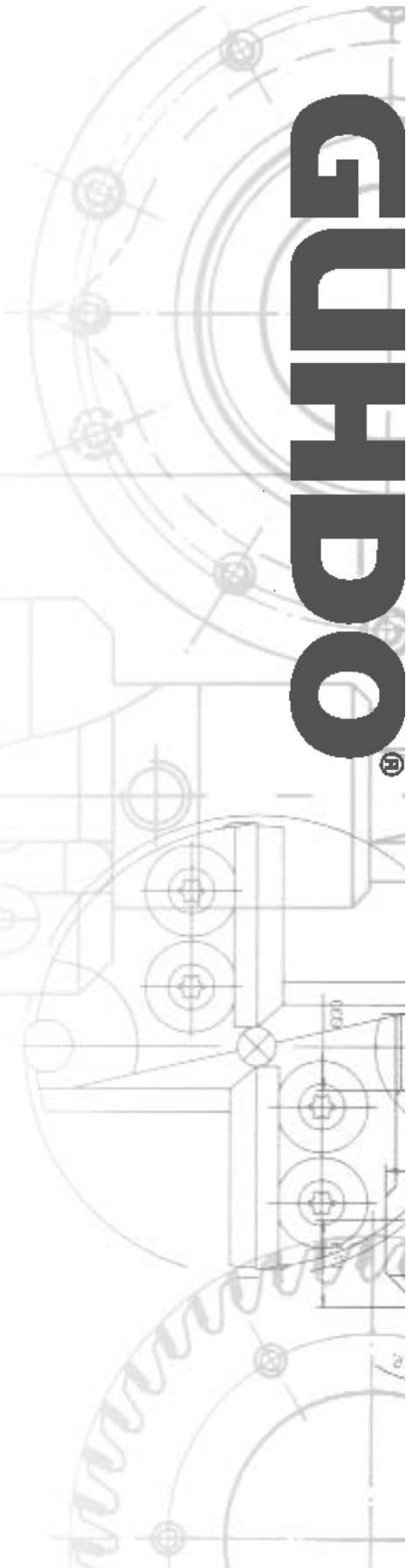



Other Product Literature Available:

CNC Tooling Catalog  
Diamond Tooling Catalog

**ISO 9001 CERTIFIED**

**GUHDO USA, INC.**

1135 JVL Industrial Ct  
MARIETTA, GA 30066

Tel. (800) 544-8436 • (770) 592-4766  
Fax (770) 592-1714

Visit our website at [www.guhdo.com](http://www.guhdo.com) or  
e-mail us at [postmaster@guhdo.com](mailto:postmaster@guhdo.com).



# Thin TCT Planer Knives

**GUHDO®**

Available with a 10 mm carbide inlay and C2 carbide grade. To convert to inch dimensions, divide the following sizes by 25.4 mm. Cut to size lengths available upon request.

**1001**

TCT planer knives for electric hand planers available upon request

L x H x T	Part No.	L x H x T	Part No.	L x H x T	Part No.
		60 x 30 x 3	1001.060.30		
		80 x 30 x 3	1001.080.30		
100 x 25 x 3	1001.100.25	100 x 30 x 3	1001.100.30		
110 x 25 x 3	1001.110.25	110 x 30 x 3	1001.110.30		
120 x 25 x 3	1001.120.25	120 x 30 x 3	1001.120.30		
130 x 25 x 3	1001.130.25	130 x 30 x 3	1001.130.30		
140 x 25 x 3	1001.140.25	140 x 30 x 3	1001.140.30		
150 x 25 x 3	1001.150.25	150 x 30 x 3	1001.150.30		
		160 x 30 x 3	1001.160.30		
		170 x 30 x 3	1001.170.30		
		180 x 30 x 3	1001.180.30		
		200 x 30 x 3	1001.200.30		
		210 x 30 x 3	1001.210.30		
230 x 25 x 3	1001.230.25	230 x 30 x 3	1001.230.30		
		250 x 30 x 3	1001.250.30		
260 x 25 x 3	1001.260.25	260 x 30 x 3	1001.260.30		
		300 x 30 x 3	1001.300.30		
310 x 25 x 3	1001.310.25	310 x 30 x 3	1001.310.30	310 x 35 x 3	1001.310.35
		350 x 30 x 3	1001.350.30	350 x 35 x 3	1001.350.35
		400 x 30 x 3	1001.400.30	400 x 35 x 3	1001.400.35
410 x 25 x 3	1001.410.25	410 x 30 x 3	1001.410.30	410 x 35 x 3	1001.410.35
		450 x 30 x 3	1001.450.30	450 x 35 x 3	1001.450.35
		500 x 30 x 3	1001.500.30	500 x 35 x 3	1001.500.35
510 x 25 x 3	1001.510.25	510 x 30 x 3	1001.510.30	510 x 35 x 3	1001.510.35
		530 x 30 x 3	1001.530.30	530 x 35 x 3	1001.530.35
		600 x 30 x 3	1001.600.30	600 x 35 x 3	1001.600.35
		610 x 30 x 3	1001.610.30	610 x 35 x 3	1001.610.35
		630 x 30 x 3	1001.630.30	630 x 35 x 3	1001.630.35
		640 x 30 x 3	1001.640.30	640 x 35 x 3	1001.640.35
		710 x 30 x 3	1001.710.30	710 x 35 x 3	1001.710.35
810 x 25 x 3	1001.810.25	810 x 30 x 3	1001.810.30	810 x 35 x 3	1001.810.35
		860 x 30 x 3	1001.860.30	860 x 35 x 3	1001.860.35

# Thin HSS Planer Knives

**1501**

Supplied with 18% tungsten content. Provides longer runs than M2 HSS knives. Cut to size lengths available upon request.

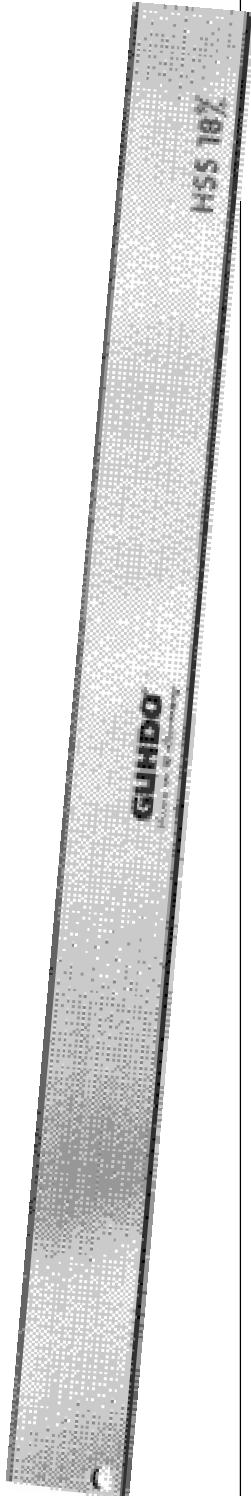

HSS Planer Knives for electric hand planers available upon request.

Thin Stellite Planer Knives available upon request.

L x H x T	Part No.	L x H x T	Part No.
60 x 30 x 3	1501.060.30	60 x 35 x 3	1501.060.35
80 x 30 x 3	1501.080.30	80 x 35 x 3	1501.080.35
100 x 30 x 3	1501.100.30	100 x 35 x 3	1501.100.35
120 x 30 x 3	1501.120.30	120 x 35 x 3	1501.120.35
130 x 30 x 3	1501.130.30	130 x 35 x 3	1501.130.35
150 x 30 x 3	1501.150.30	150 x 35 x 3	1501.150.35
160 x 30 x 3	1501.160.30	160 x 35 x 3	1501.160.35
170 x 30 x 3	1501.170.30	170 x 35 x 3	1501.170.35
180 x 30 x 3	1501.180.30	180 x 35 x 3	1501.180.35
210 x 30 x 3	1501.210.30	210 x 35 x 3	1501.210.35
230 x 30 x 3	1501.230.30	230 x 35 x 3	1501.230.35
240 x 30 x 3	1501.240.30	240 x 35 x 3	1501.240.35
250 x 30 x 3	1501.250.30	250 x 35 x 3	1501.250.35
260 x 30 x 3	1501.260.30	260 x 35 x 3	1501.260.35
300 x 30 x 3	1501.300.30	300 x 35 x 3	1501.300.35
310 x 30 x 3	1501.310.30	310 x 35 x 3	1501.310.35
350 x 30 x 3	1501.350.30	350 x 35 x 3	1501.350.35
400 x 30 x 3	1501.400.30	400 x 35 x 3	1501.400.35
410 x 30 x 3	1501.410.30	410 x 35 x 3	1501.410.35
450 x 30 x 3	1501.450.30	450 x 35 x 3	1501.450.35
500 x 30 x 3	1501.500.30	500 x 35 x 3	1501.500.35
510 x 30 x 3	1501.510.30	510 x 35 x 3	1501.510.35
530 x 30 x 3	1501.530.30	530 x 35 x 3	1501.530.35
600 x 30 x 3	1501.600.30	600 x 35 x 3	1501.600.35
610 x 30 x 3	1501.610.30	610 x 35 x 3	1501.610.35
630 x 30 x 3	1501.630.30	630 x 35 x 3	1501.630.35
640 x 30 x 3	1501.640.30	640 x 35 x 3	1501.640.35
710 x 30 x 3	1501.710.30	710 x 35 x 3	1501.710.35
810 x 30 x 3	1501.810.30	810 x 35 x 3	1501.810.35

# Carbide Tipped Corrugated Bars



Carbide tipped corrugated steel is commonly used on hard woods and highly abrasive composite materials. Available with 60° corrugations and C2 carbide. Sizes not listed available on request.

**1090**

Bar L x H x T	Carbide Inlay	Part No.
25" x 1-1/2" x 5/16"	15mm	1090S635I15
25" x 1-1/2" x 5/16"	20mm*	1090S635I20
25" x 2" x 5/16"	20mm*	1090U635I20
25" x 2" x 5/16"	25mm*	1090U635I25
25" x 2-3/4" x 5/16"	35mm*	1090C635I35
Cut Sizes Available:		
4" x 1-1/2" x 5/16"	15mm	1090.000.02
6" x 1-1/2" x 5/16"	15mm	1090.000.01
9" x 1-1/2" x 5/16"	15mm	1090.000.03
2" x 2" x 5/16"	25mm*	1090.000.04
4" x 2" x 5/16"	25mm*	1090.000.05
6" x 2" x 5/16"	25mm*	1090.000.06
9" x 2" x 5/16"	25mm*	1090.000.07

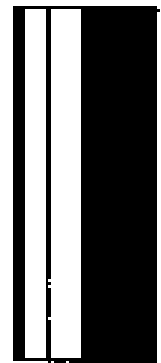

# HSS Corrugated Steel Bars

Standard M2 Grade  
with 16-60° corrugations.

Available on request:  
Cut-to-size knives  
Flat back knives

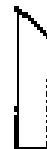

**1591**

Bar L x H x T		Part No.
25 x 1-1/2 x 5/16	M2	1591S635I60
25 x 1-3/4 x 5/16	M2	1591T635I60
25 x 2 x 5/16	M2	1591U635I60
25 x 2-1/4 x 5/16	M2	1591Z635I60
25 x 2 1/2 x 5/16	M2	1591G635I60
25 x 2 3/4 x 5/16	M2	1591C635I60

# Inch Dimension Saw Program

**Combination Saw Blades**

#2000.250C50	10" x .126" x 5/8" Z= 50	15 degree
#2000.300C60	12" x .126 x 1" Z= 60	15 degree
#2000.350C70	14" x .160 x 1" Z= 70	10 degree

**General Purpose ATB Saw Blades**

#2000.250A12	10" x .126" x 1" Z= 12	15 degree
#2000.250A30	10" x .126" x 5/8" Z= 30	20 degree
#2000.250A40	10" x .126" x 5/8" Z= 40	12 degree
#2000.250A60	10" x .126" x 5/8" Z= 60	10 degree
#2000.250A80	10" x .126" x 5/8" Z= 80	5 degree
#2000.300A36	12" x .126" x 1" Z= 36	15 degree
#2000.300A48	12" x .126" x 1" Z= 48	12 degree
#2000.300A60	12" x .126" x 1" Z= 60	10 degree
#2000.300A72	12" x .126" x 1" Z= 72	12 degree
#2000.300A96	12" x .126" x 1" Z= 96	10 degree
#2000.350A42	14" x .138" x 1" Z= 42	15 degree
#2000.350A60	14" x .138" x 1" Z= 60	10 degree
#2000.350A84	14" x .138" x 1" Z= 84	10 degree
#2000.350A18	14" x .134" x 1" Z= 108	10 degree
#2000.400A48	16" x .142" x 1" Z= 48	15 degree
#2000.400A84	16" x .138" x 1" Z= 84	12 degree
#2000.400A12	16" x .140" x 1" Z= 120	10 degree
#2000.450A80	18" x .181" x 1" Z= 80	10 degree
#2000.450A10	18" x .181" x 1" Z= 100	10 degree

**Thin Kerf ATB Saw Blades**

#2000T250A60	10" x .110" x 5/8" Z= 60	10 degree
#2000T250A80	10" x .090" x 1" Z= 80	15 degree
#2000T300A72	12" x .110" x 1" Z= 72	12 degree
#2000P300A96	12" x .094" x 1" Z= 96	12 degree

**General Purpose TCG Saw Blades**

#2039.251.30	250 x 3.2 x 30 Z= 60	10 degree
#2000.250T60	10" x .126" x 5/8" Z= 60	10 degree
#2000.250T80	10" x .126" x 5/8" Z= 80	5 degree
#2000.300T48	12" x .145" x 1" Z= 48	10 degree
#2000.300T60	12" x .145" x 1" Z= 60	10 degree
#2000.300T72	12" x .126" x 1" Z= 72	10 degree
#2000.300T80	12" x .126" x 1" Z= 80	10 degree
#2000.300T10	12" x .130" x 1" Z= 100	10 degree
#2000.350T60	14" x .138" x 1" Z= 60	10 degree
#2000.350T84	14" x .137" x 1" Z= 84	10 degree
#2000.400T18	16" x .140" x 1" Z= 108	12 degree
#2000.400T12	16" x .138" x 1" Z= 120	10 degree
#2000.450T10	18" x .160" x 1" Z= 100	10 degree

**No Melt Saw Blade for Plastics**

#2000P250T80	10" x .100 x 5/8" Z= 80	5 degree
--------------	-------------------------	----------

**Laminate - High Angle 30 degree ATB Saw Blades**

#2000N220A64	220 x 3.2 x 30 Z= 64	-5 degree
#2000N250A80	10" x .114" x 5/8" Z= 80	-5 degree
#2000M250A80	10" x .106" x 5/8" Z= 80	(45 degree)
#2000N301A96	12" x .126" x 1" Z= 96	-5 degree
#2000N300A96	303 x 3.2 x 30 Z= 96	-5 degree
#2000N351A10	14" x .150" x 1" Z= 100	-5 degree
#2000N350A10	350 x 3.2 x 30 Z= 100	-5 degree
#2000N400A12	16" x .157" x 1" Z= 120	-5 degree

# Inch Dimension Saw Program



Continued from previous page.

## Radial Arm Saw Blade - ATB w/raker

#2000.250A20	10" x .134" x 5/8" Z= 20	0 degree
#2000.300A30	12" x .150" x 1" Z= 30	0 degree
#2000.350A40	14" x .161" x 1" Z= 40	0 degree
#2000.400A40	16" x .161" x 1" Z= 40	0 degree

## Pistorius Mitre Saw Blades - Combination Grind

#2000.300A10	12" x .126" x 5/8" Z= 100	-2 degree
#2000N300T10	12" x .134" x 5/8" Z= 100	-5 degree
#2000.350A10	14" x .138" x 5/8" Z= 100	-2 degree

## Solid Surface Saw Blade - Triple Chip

#2000S220T64	220 x 3.4 x 30 Z= 64	-6 degree
#2000S250T80	10" x .126" x 5/8" Z= 80	-6 degree
#2000S300T10	12" x .138" x 1" Z= 100	-6 degree
#2000S350T10	14" x .158" x 1" Z= 100	-6 degree

## Non-Ferrous Saw Blades - Triple Chip

#2000N250T60	10" x .125" x 5/8" Z= 60	-5 degree
#2000N250T72	10" x .125" x 5/8" Z= 72	-5 degree
#2000N250T80	10" x .114" x 5/8" Z= 80	-5 degree
#2000N250T10	10" x .115" x 5/8" Z= 100	-5 degree
#2000N300T72	12" x .126" x 1" Z= 72	-5 degree
#2000N300T96	12" x .126" x 1" Z= 96	-5 degree
#2000N350T10	14" x .146" x 1" Z= 100	-5 degree
#2000N400T10	16" x .146" x 1" Z= 100	-5 degree

## Steel Cutting Saw Blades - Flat w/ Chamfer

#2000S300F60	12" x .080" x 1" Z= 60	0 degree
#2000S300F80	12" x .080" x 1" Z= 80	0 degree
#2000S350F80	14" x .100" x 1" Z= 80	0 degree
#2000S350F10	14" x .100" x 1" Z= 100	0 degree

## Rip Saw Blades for Table Saws - Flat Grind

#2000.250F18	10" x .118" x 5/8" Z= 18	20 degree
#2000.250F24	10" x .145" x 5/8" Z= 24	20 degree
#2000.300F24	12" x .160" x 1" Z= 24	20 degree
#2000.350F24	14" x .138" x 1" Z= 24	20 degree

## Rip Saw Blades for Table Saws - TCG for Glue-Line

#2000.250T30	10" x .146" x 5/8" Z= 30	20 degree
#2000.300T30	12" x .150" x 1" Z= 30	20 degree
#2000.350T36	14" x .150" x 1" Z= 36	20 degree
#2000.400T36	16" x .170" x 1" Z= 36	20 degree

## Rip Saw Blades for High Production Machines - Flat Grind

#2000.250F20	10" x .130" x 3-1/8" Z= 18	20 degree
#2000.301F24	12" x .150" x 3-1/8" Z= 24	20 degree
#2000.300F36	12" x .126" x 3-1/8" Z= 36	20 degree
#2000.350F28	14" x .150" x 3-1/8" Z= 28	20 degree

## Rip Saw Blades for High Production Machines - TCG for Glue-Line

#2000G250T30	10" x .130" x 3-1/8" Z= 30	20 degree
#2000G300T36	12" x .150" x 3-1/8" Z= 36	20 degree
#2000R300T36	300 x 4.0 x 70 DKN Z= 36	20 degree
#2000G350T42	14" x .150" x 3-1/8" Z= 42	20 degree
#2000D350T42	14" x .150" x 2" Z= 42 1/.563"/5"	20 degree



## Crosscut Blade For Radial Arm Saw

**2109**

With alternate top bevel for cross cutting soft and hard woods on radial arm saws. The negative hook prevents the saw blade from climb-cutting when cutting the material. Supplied in "Piano Plus"(low noise) version.

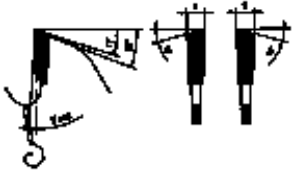

## Special Saw Blade For Construction

**2301**

An all purpose saw blade with special carbide, large gullets and large tip to body clearance. Designed to cut a variety of materials that may include nails, staples, etc.without saw tip damage.

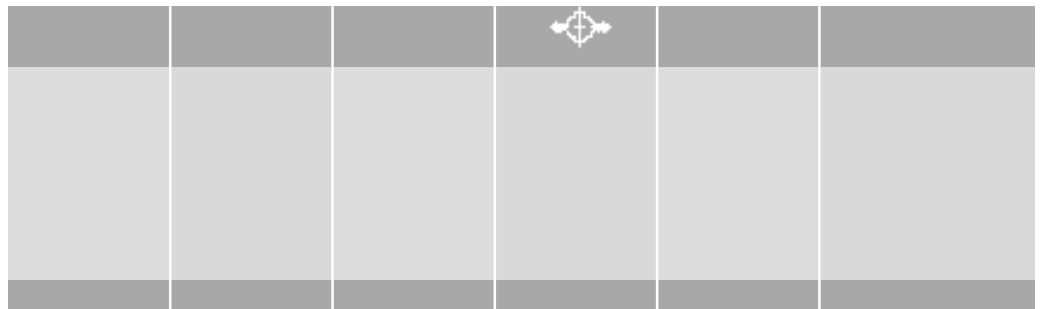
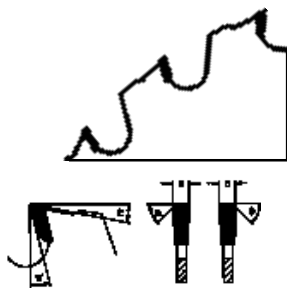

## Rip Saw Blades With Chip Limitors

### 2001 LFZ 1

With square teeth for ripping hard and softwoods.

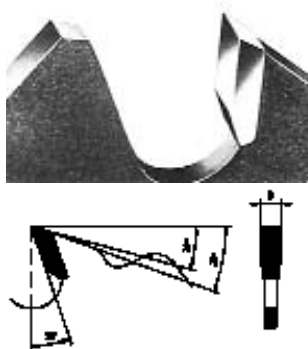



D	B	d	Z		Part No.
250	3.2	30	12	2/10/60	2001.250.30
300	3.4	30	12	KNL	2001.300.30
300	3.8	30	8	CNL	2001.301.30
350	3.8	30	16	CNL	2001.350.30
350	3.8	30	10	CNL	2001.351.30
355	3.8	30	16	CNL	2001.355.30
400	4.1	30	12	CNL	2001.401.30
400	3.8	30	18	KNL	2001.400.30
450	4.2	30	20	KNL	2001.450.30
500	4.5	30	22	KNL	2001.500.30

KNL = Supplied with pinholes (2/10/60 and 2/7/42)  
CNL = Supplied with pinholes (2/7/42+2/9/46.4+2/10/60)

### 2002 LFZ 2

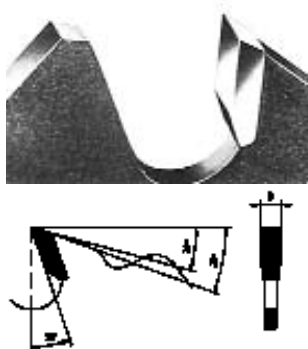
With square teeth for ripping and cross-cutting in hard and softwoods.



D	B	d	Z		Part No.
200	3.2	30	14		2002.200.30
250	3.2	30	18	2/10/60	2002.250.30
300	3.4	30	20	KNL	2002.300.30
350	3.7	30	24	CNL	2002.350.30
400	4.0	30	28	KNL	2002.400.30
450	4.0	30	32	KNL	2002.450.30
500	4.0	30	32	KNL	2002.500.30

KNL = Supplied with pinholes (2/10/60 and 2/7/42)  
CNL = Supplied with pinholes (2/7/42+2/9/46.4+2/10/60)

# Rip Saw Blades With Chip Limitors

**GUHDO®**

With alternate top bevel teeth for ripping  
and crosscutting all natural timbers.

## 2003 LWZ 3

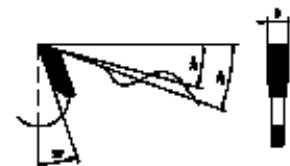

D	B	d		Z	Part No.
240	3.2	30	2/7/42	24	2003.240.30
250	3.2	30	CNL	24	2003.250.30
270	3.2	30		24	2003.270.30
280	3.4	30	KNL	28	2003.280.30
300	3.4	30	KNL	28	2003.300.30
315	3.4	30	CNL	28	2003.315.30
350	3.7	30	CNL	32	2003.350.30
355	3.2	30		16	2003.356.30
355	3.7	30	CNL	32	2003.355.30
370*	4.0	30		18	2003.371.30
370	4.5	30		26	2003.370.30
380	3.2	30		16	2003.380.30
400	4.0	30	KNL	36	2003.400.30
410	4.0	30		20	2003.411.30
410	4.5	30		28	2003.410.30
450*	4.0	30	KNL	40	2003.450.30
500	4.0	30	KNL	44	2003.500.30
550	4.6	30	KNL	48	2003.550.30

KNL = Supplied with combination pinholes (2/10/60 & 2/7/42)  
 CNL = Supplied with pinholes (2/7/42+2/9/46.4 & 2/10/60)  
 \*Denotes with cooling slots

# Rip Saw Blades

Rip saw blade with alternate top bevel and  
large gullets for ripping soft and hard woods.  
Supplied in "Piano Plus" (low noise) version.

## 2104

D	B	d	Z		Part Number
250	3.2	30	24	CNL	2104.250.31
300	3.2	30	28	KNL	2104.300.31
350	3.7	30	32	CNL	2104.350.31
400	4.0	30	36	KNL	2104.400.31
450	4.2	30	40	KNL	2104.450.31

KNL = Supplied with combination pinholes (2/10/60 & 2/7/42)  
 CNL = Supplied with pinholes (2/7/42+2/9/46.4 & 2/10/60)

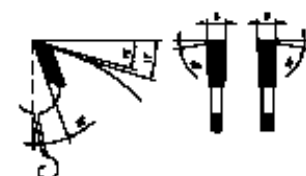

# Rip Saw Blades

**GUHDO®**

With square teeth and a large gullet area that provide easy chip removal.  
For use on single line and multiple rip machines.

D	B	d		Z	Part No.
200	3.0	30		14	2005.200.30
250	3.3	30	CNL	18	2005.250.30
300	3.5	30	CNL	20	2005.300.30
300	3.5	60	DKN 22 x 6	20	2005.300.60
300	3.5	70	DKN 20 x 6	20	2005.300.70
300	3.5	75	DKN 16.5x5.5	20	2005.300.75
350	3.8	30	CNL	24	2005.350.30
350	3.8	70	DKN 20 x 6	24	2005.350.70
350	3.8	80	DKN 12.3x5.5	24	2005.350.80
400	4.2	30	CNL	28	2005.400.30
450*	4.2	30	CNL	32	2005.450.30
500*	4.5	30	KNL	36	2005.500.30

\*Denotes with cooling slots

KNL = Supplied with combination pinholes (2/10/60 & 2/7/42)

CNL = Supplied with pinholes (2/7/42+2/9/46.4 & 2/10/60)

DKN= Supplied with double keyway

**2005**

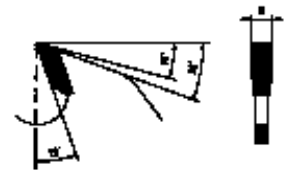

# Rip Saw Blades With Chip-Clearance

With chip limitors for reduced kickback and T.C.T. chip clearance guides for easy chipflow.  
The chip clearance guides ensure the quick removal of sawdust from the cutting area and also act to prevent the sawblade from overheating

With square teeth for hard and soft woods

D	B	d	Z	R*		Part No.
300	3.4	30	20	4	KNL	2007.300.30
350	3.8	30	16	4	CNL	2007.350.30
355	3.8	30	16	4	CNL	2007.355.30
380	3.6	30	28	4	KNL	2007.380.30
400	3.8	30	16	4	KNL	2007.400.30
450	4.2	30	20	4	KNL	2007.450.30

With alternate top bevel for ripping and crosscutting hard and soft woods

D	B	d	Z	R*		Part No.
350	3.8	30	32	4	CNL	2007.351.30
355	3.8	30	32	4	CNL	2007.356.30
400	3.8	30	36	4	KNL	2007.401.30
450	4.2	30	40	4	KNL	2007.451.30
500	4.4	30	40	4		2007.501.30
550	4.6	30	44	4	2/7/42	2007.551.30
600	4.8	30	48	4		2007.601.30

KNL = Supplied with combination pinholes (2/10/60 and 2/7/42)

CNL = Supplied with pinholes (2/7/42+2/9/46.4+2/10/60)

R= Number of guides

**2007**

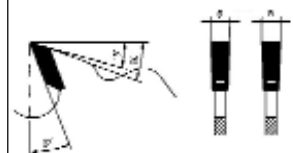

## Rip Saw Blades With Chip Limitors

### 2011 LFA 1

With square teeth for ripping softwoods.

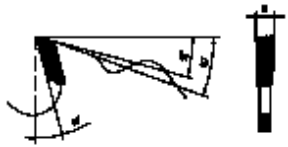

D	B	b	d		Z	Part Number
250	3.2	2.2	70	DKN 20 x 6	16	2011.250.70
300	3.2	2.2	70	DKN 20 x 6	20	2011.300.70
350	3.2	2.2	70	DKN 20 x 6	24	2011.350.70

### 2012 LFA 2

With square teeth for ripping hardwoods.

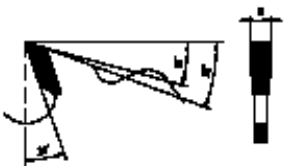

D	B	b	d		Z	Part Number
210	3.2	2.2	75	DKN 20 x 6	34	2012.210.75
220	3.2	2.2	60	DKN 15 x 5	34	2012.220.60
220	3.2	2.2	75	DKN 20x 6	34	2012.220.75
250	3.2	2.2	70	DKN 20 x 6	24	2012.250.70
250	3.2	2.2	75	DKN 20 x 6	24	2012.250.75
300	3.2	2.2	70	DKN 20 x 6	28	2012.300.70

## Squaring Rip Saw Blade

### 2014

For use on straight line rip saw for ripping soft and hard wood.

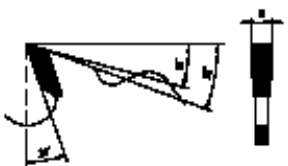

D	B	b	d		Z	Part No.
260	4.2	2.6	60	DKN 15 x 6	20	2014.260.60
300	4.2	2.6	30		24	2014.300.30
300	4.2	2.6	70	DKN 20 x 6	24	2014.300.70
350	4.2	2.6	30		28	2014.350.30
350	4.2	2.6	70	DKN 20 x 6	28	2014.350.70

350 mm supplied with cooling slots

# Special Application Rip Saw Blades

**GUHDO®**

For ripping thin material on multiple  
rip saws. With chip limitors and two  
carbide tipped clearing guides.

**2013**



D	B	b	d	Z	Part Number
220	3.4	2.2	60	16+2	2013.220.30
250	2.8	1.8	80 DKN 12x4	16+2	2013.250.80
250	3.4	2.2	55 DKN 20x6	16+2	2013.250.55
250	3.4	2.2	70 DKN 20x6	16+2	2013.250.70
250	3.4	2.2	75 DKN 20x6	16+2	2013.250.75
300	3.4	2.2	70 DKN 20x6	20+2	2013.300.70
300	3.4	2.2	75 DKN 18x5	20+2	2013.300.75
300	3.4	2.2	80 DKN 12x4	20+2	2013.300.80
300	3.4	2.2	80 DKN 22x6	20+2	2013.300.81
350	4.0	2.8	70 DKN 20x6	20+2	2013.350.70
350	4.0	2.8	75 DKN 18x5	20+2	2013.350.75



For ripping thick (wet or dry) material on  
multiple rip saws. With two carbide tipped  
chip clearing guides and two carbide  
wiper slots. Without chip limitors.

**2015**



D	B	b	d	Z	Part Number
250	3.6	2.4	70 DKN 22x8	16+2+2	2015.250.70
300	3.4	2.2	70 DKN 20x6	20+2+2	2015.300.70
300	3.4	2.2	80 DKN 20x6	20+2+2	2015.300.80
300	3.2	2.2	80 DKN 12x5	20+2+2	2015.300.81
300	3.5	2.5	80 DKN 12x5	20+2+2	2015.300.82
320	3.4	2.2	70 DKN 20x6	20+2+2	2015.320.70
320	3.4	2.2	80 DKN 20x6	20+2+2	2015.320.80
350	4.0	2.8	70 DKN 20x6	20+2+2	2015.350.70
350	4.0	2.8	80 DKN 20x6	20+2+2	2015.350.80
380	4.0	2.8	75 DKN 20x6	20+2+4	2015.380.75
400	4.2	2.8	70 DKN 20x6	20+2+4	2015.400.70
400	5.2	4.0	70 DKN 12x5	20+2+6	2015.400.71
400	4.2	2.8	80 DKN 20x6	20+2+4	2015.400.80
450	4.6	3.2	80 DKN 20x6	20+2+4	2015.450.80
500	5.2	3.9	70 DKN 12x5	20+2+6	2015.500.70
550	5.2	3.9		24+2+6	2015.550.00

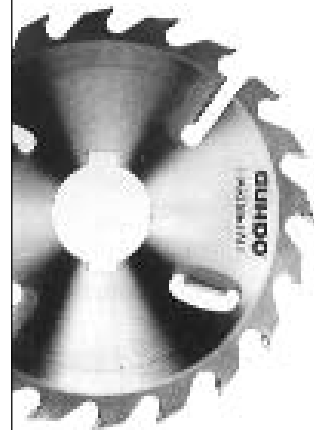

# Standard ATB Circular Saw Blades

## 2020 QW

Designed for ripping and cross cutting thick solid woods.

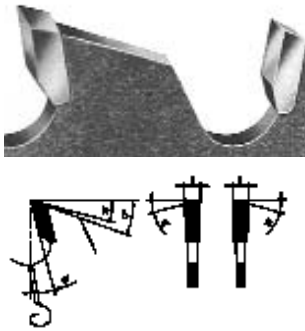

D	B	d		Z	Part No.
150	2.6	30		18	2020.150.30
180	2.6	30	2/7/42	22	2020.180.30
200	2.8	30	2/7/42	24	2020.200.30
250	3.2	30	CNL	30	2020.250.30
300	3.2	30	KNL	36	2020.300.30
320	3.2	30	2/7/42	36	2020.320.30
350	3.5	30	CNL	42	2020.350.30
400	3.5	30	2/10/60	48	2020.400.30
450	4.0	30	KNL	54	2020.450.30
500	4.0	30	KNL	60	2020.500.30

KNL = Supplied with pinholes (2/10/60, 2/7/42)  
CNL = Supplied with pinholes (2/7/42, 2/9/46.4 & 2/10/60)

## 2021 UW

Same as No. 2020 but providing a better finish.

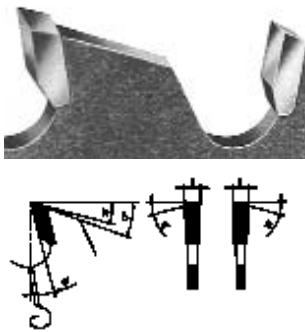

D	B	d		Z	Part No.
150	2.6	30		24	2021.150.30
180	2.6	30	2/7/42	30	2021.180.30
200	2.8	30	2/7/42	34	2021.200.30
250	3.2	30	CNL	42	2021.250.30
250	3.2	30	CNL	42	2121.250.31
250	3.2	32		42	2021.250.32
280	3.2	30	KNL	48	2021.280.30
300	3.2	30	KNL	48	2021.300.30
300	3.2	30	CNL	48	2121.300.31
300	3.2	60		48	2021.300.60
315	3.2	30	CNL	48	2021.315.30
350	3.5	30	CNL	54	2021.350.30
350	3.5	30	CNL	54	2121.350.31
350	3.5	35		54	2021.350.35
350	3.5	50	KN 8X8	54	2021.350.50
350	3.5	60		54	2021.350.60
350	3.5	80		54	2021.350.80
400	3.5	30	2/10/60	60	2021.400.30
400	3.5	35		60	2021.400.35
400	3.5	50	KN 8X8	60	2021.400.50
450	4.0	30	KNL	66	2021.450.30
500	4.0	30	KNL	72	2021.500.30

KNL = Supplied with combination pinholes (2/10/60, 2/7/42)  
KN 8X8 = Supplied with 8mm x 8mm keyway  
 = Supplied in "Piano Plus" (low noise) version  
CNL = Supplied with pinholes (2/7/42, 2/9/46.4 & 2/10/60)

# Standard ATB Circular Saw Blades

**GUHDO®**

Same as No. 2021, also suitable for thinner material.



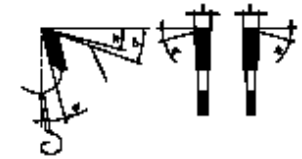

## 2022 GW

D	B	d		Z	Part No.
150	2.6	30		30	2022.150.30
180	2.6	30	2/7/42	36	2022.180.30
200	2.8	30	2/7/42	42	2022.200.30
250	3.2	30	CNL	48	2022.250.30
300	3.2	30	KNL	60	2022.300.30
350	3.5	30	CNL	72	2022.350.30
350	3.5	35		72	2022.350.35
400	3.5	30	2/10/60	84	2022.400.30
			KNL = Supplied with combination pinholes (2/10/60, 2/7/42) CNL= Supplied with pinholes (2/7/42, 2/9/46.4 & 2/10/60)		



Designed for cross cutting solid woods up to 2" thick.

## 2023 KW

D	B	d		Z	Part No.
150	2.6	30		36	2023.150.30
180	2.6	30	2/7/42	42	2023.180.30
200	2.8	30	2/7/42	48	2023.200.30
250	3.2	30	CNL	60	2023.250.30
250	3.2	30	CNL 	60	2123.250.31
250	3.2	32		60	2023.250.32
280	3.2	30	KNL	68	2023.280.30
300	3.2	30	KNL	72	2023.300.30
300	3.2	30	CNL 	72	2123.300.31
315	3.2	30	CNL	72	2023.315.30
320	3.2	30	2/7/42	72	2023.320.30
350	3.5	30	CNL	84	2023.350.30
350	3.5	30	CNL 	84	2123.350.31
350	3.5	35		84	2023.350.35
400	3.5	30	2/10/60	96	2023.400.30
400	3.5	35		96	2023.400.35
400	3.5	50	KN 8X8	96	2023.400.50
450	4.0	30	KNL	108	2023.450.30

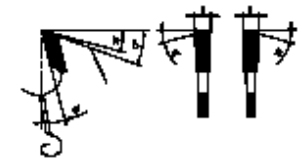

KNL = Supplied with combination pinholes (2/10/60, 2/7/42)  
 8X8 = Supplied with 8mm x 8mm keyway  
 = Supplied in "Piano Plus" (low noise) version  
 CNL= Supplied with pinholes (2/7/42, 2/9/46.4 & 2/10/60)





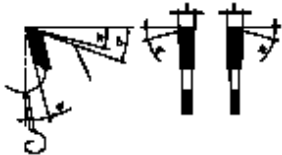

# Standard ATB Circular Saw Blades

## 2024 VW

Designed for cross cutting solid woods up to 1" thick.



D	B	d		Z	Part No.
150	2.6	30		48	2024.150.30
180	2.6	30	2/7/42	56	2024.180.30
200	2.8	30	2/7/42	64	2024.200.30
250	3.2	30	CNL	80	2024.250.30
250	3.2	30	CNL 	80	2124.250.31
250	3.2	32		80	2024.250.32
300	3.2	30	KNL	96	2024.300.30
300	3.2	30	CNL 	96	2124.300.31
330	3.2	30	2/10/60	100	2024.330.30
350	3.5	30	CNL	108	2024.350.30
350	3.5	30	CNL 	108	2124.350.31
350	3.5	35		108	2024.350.35
350	3.5	50	KN 8X8	108	2024.350.50
400	3.5	30	2/10/60	120	2024.400.30
400	3.5	50	KN 8X8	120	2024.400.50
450	4.0	30	KNL	132	2024.450.30
500	4.6	30		144	2024.500.30

KNL = Supplied with combination pinholes (2/10/60, 2/7/42)  
 8X8 = Supplied with 8mm x 8mm keyway  
 = Supplied in "Piano Plus" (low noise) version  
 CNL = Supplied with pinholes (2/7/42, 2/9/46.4 & 2/10/60)

# Thin Kerf Circular Saw Blades



Thin kerf saw blade with alternate top grind. We recommend saw collars at least 1/3 of the saw diameter.

For ripping exotic woods or veneers. Recommended material thickness up to 1-1/2".

D	B	d		Z	Part No.
150	2.0	30		24	2025.150.30
180	2.0	30		30	2025.180.30
200	2.0	30		34	2025.200.30
250	2.1	30	2/10/60	42	2025.250.30
300	2.2	30	2/10/60	48	2025.300.30
350	2.4	30	2/10/60	54	2025.350.30

## 2025 UWD

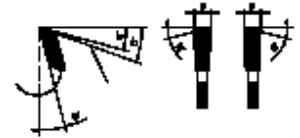

For ripping and crosscutting exotic woods and veneers. A constant feed speed of the work piece is recommended.

D	B	d		Z	Part No.
150	2.0	30		48	2027.150.30
180	2.0	30		56	2027.180.30
200	2.0	30		64	2027.200.30
250	2.1	30	2/10/60	80	2027.250.30
300	2.2	30	2/10/60	96	2027.300.30
350	2.4	30	2/10/60	108	2027.350.30

## 2027 VWD

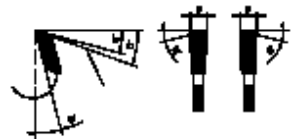

Thin kerf and aggressive hook angle for sizing solid woods, veneers and lattice material.

D	B	d		Z	Part No.
150	2.4	30		24	2026.150.30
180	2.4	30		30	2026.180.30
200	2.4	30		34	2026.200.30
250	2.4	30	2/10/60	42	2026.250.30
300	2.4	30	2/10/60	48	2026.300.30
350	2.4	30	2/10/60	54	2026.350.30

## 2026 LWD



# Multi-Tooth Saw Blades

## 2028

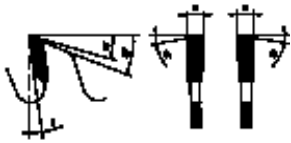
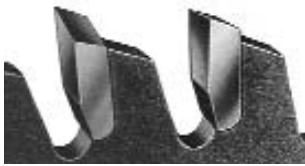

With alternate top bevel, positive hook angle for table saws. A fine cutting saw especially suitable for clean cutting of aluminum extrusions, and acrylics.

D	B	d		Z	Part No.
150	2.2	30		60 •	2028.150.30
200	2.2	30		80 •	2028.200.30
250	2.2	30	2/10/60	100 •	2028.250.30
300	2.2	30	2/10/60	100 •	2028.300.30

• Supplied with copper plugs

## 2029

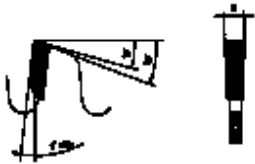

With square teeth and negative hook especially suitable for tearout free cutting of plastic and aluminum extrusions.

D	B	d	Z	Part Number
250	2.2	30	100 •	2029.250.30
300	2.2	30	120 •	2029.300.30

• Supplied with copper plugs

# Saw Blades For Plastic Sheets

## 2030

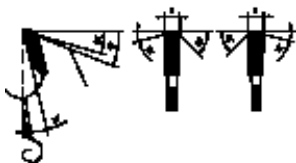

With alternate "off set" high pointed teeth. The support flanges must equal at least 1/3 of the saw blade diameter. Especially suitable for the fine cutting of homogenous materials, plastic sheets up to 8 mm thick (compressed paper, compressed fibre). Suitable for picture frames.

D	B	d		Z	Part No.
150	2.0	30		48	2030.150.30
180	2.0	30		56	2030.180.30
200	2.0	30		64	2030.200.30
250	2.1	30	2/10/60	80	2030.250.30
300	2.2	30	2/10/60	96	2030.300.30
350	2.4	30	2/10/60	108	2030.350.30



• Supplied with copper plugs

# Hollow Face Saw Blades

**GUHDO®**

Saw blade designed to cut double sided materials without scoring. Especially designed for use on vertical panel saws. Series No. 2037 and 2137 with 10° positive hook. Series No. 2138 with 6° negative hook.

**2037**  
**2137**  
**2138**

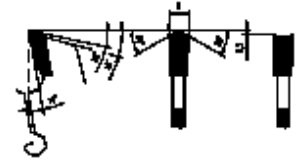
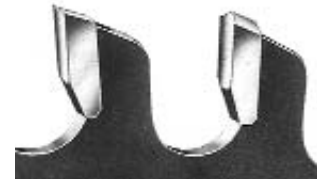

D	B	d	Z		Part No.
220	3.2	30	42	2/7/42	2037.220.30
250	3.2	30	48	CNL	2037.250.30
303	3.2	30	60	KNL	2037.300.30
303	3.2	30	60 	KNL	2137.303.31
303	3.2	30	60 neg 	KNL	2138.303.31
350	3.5	30	72	2/10/60	2037.350.30

 = Supplied in "Piano Plus" (low noise) version  
KNL = Supplied with combination pinholes (2/10/60 and 2/7/42)  
CNL = Supplied with pinholes (2/7/42+2/9/46.4+2/10/60)



Same application as above. Especially designed for use on table saws without scoring. Positive rake.

**2041**

D	B	d	Z		Part No.
160	2.9	20	36 •	2/6/32	2041.160.20
180	2.9	30	36 •		2041.180.30
190	2.9	30	42 •	2/7/42	2041.190.30
200	2.9	30	48 •		2041.200.30
203	2.9	5/8	48 •		2041.203.58
220	2.9	30	48 •	2/7/42	2041.220.30
250	2.9	30	60 •	CNL	2041.250.30
280	2.9	30	68 •	KNL	2041.280.30
300	2.9	30	72 	KNL	2141.300.31
*303	3.2	30	56 	KNL	2141.303.31
350	2.9	30	84 •	2/10/60	2041.350.30
400	2.9	30	96 •	2/10/60	2041.400.30

 = Supplied in "Piano Plus" (low noise) version  
\* = Supplied in wood box  
• = Supplied with copper plugs  
KNL = Supplied with combination pinholes (2/10/60 and 2/7/42)  
CNL = Supplied with pinholes (2/7/42+2/9/46.4+2/10/60)



# Saw Blade For Solid Surface Materials

**GUHDO®**

Special grind ideal for cutting solid surface materials.  
Also suitable for cutting acrylics.

**2044**

D	B	d	Z		Part No.
250	2.8	30	60	CNL	2044.250.30
250	2.8	30	80	CNL	2044.251.30
300	3.0	30	96	KNL	2044.300.30
350	3.3	30	108	KNL	2044.350.30
		KNL = Supplied with combination pinholes (2/10/60 and 2/7/42)			
		CNL = Supplied with pinholes (2/7/42+2/9/46.4+2/10/60)			

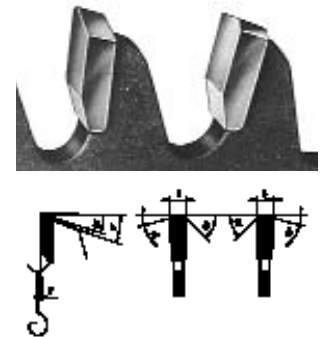

# Special Saw Blade For Sheet Steel Building Components

Multi tooth saw blade with triple chip teeth. This blade is designed for parting cuts in hard foam or multiplex boards with sheet steel on one or both sides.

**2048**

D	B	d	Z	Part Number
190	3.4	20	42	2048.190.30
240	3.4	30	48	2048.240.30
250	3.4	30	48	2048.250.30
300	3.4	30 2/10/60	60	2048.300.30
320	3.4	30	60	2048.320.30
350	4.2	30 2/10/60	72	2048.350.30
500	4.2	30	96	2048.500.30
500	4.2	80	96	2048.500.80
500	4.2	110	100	2048.500.10
550	4.2	110	100	2048.550.10
600	4.2	30	120	2048.600.30
660	4.2	30	100	2048.660.30
660	4.2	30	120	2048.661.30

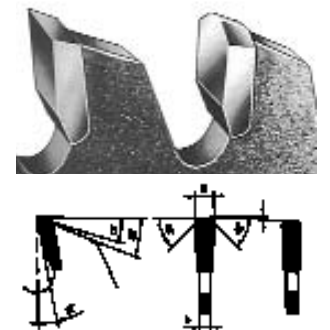

# GUHDO®

## 2049

# Saw Blade For Steel

Multipurpose saw blade for cutting Steel, Copper, Brass, Aluminum and hard plastics. Also suitable for materials that may include nails and staples without saw tip damage. Supplied in "Piano Plus" (low noise) version. Not recommended for Stainless Steel.

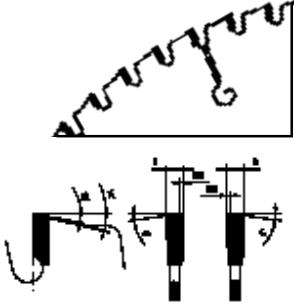

D	B	d	Z	Part Number
12"	.087"	1"	60	2049.305.25
12"	.087"	1"	80	2049.306.25
12"	.087"	30	80	2049.306.30

Maximum RPM: 2,000 for Jepson Dry Cutter 9312 and Ridgit 590

14"	.098"	1"	60	2049.355.25
14"	.098"	1"	80	2049.356.25

Maximum RPM: 1,800 for Jepson Super Dry Cutter 9312 and Elektra Beckum MC 2000

--	--	--	--	--

## 2089

# ENDUROmax

A multi-purpose saw blade with special carbide providing extremely long tool life. Produces an excellent finish in a variety of abrasive materials such as HP laminate, MDF, cement fiberboard, laminate flooring, plexi-glass, aluminum, solid surface and others.

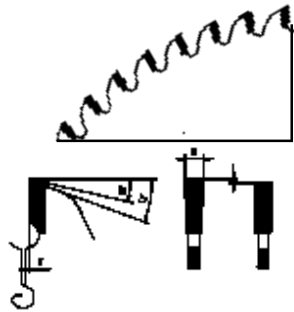

D	B	d	Z		Part No.
160	3.0	20	36	2/6/32	2089.160.21
190	3.0	30	42	2/7/42	2089.190.31
216	3.0	30	48		2089.216.31
225	3.0	30	50		2089.225.31
250	3.0	30	56	CNL	2089.250.31
303	3.2	30	68	CNL	2089.303.31

CNL = Supplied with pinholes (2/7/42+2/9/46.4+2/10/60)

## Triple Chip Saw Blades

### 2039

A general purpose saw blade designed for cutting acrylics and double sided composites with scoring. Ideal for sliding table saws.

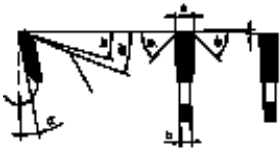

D	B	d	Z		Part No.
220	3.2	30	64 •	2/7/42	2039.220.30
240	3.2	30	54 •	2/7/42	2039.240.30
250	3.2	30	80 •	2/10/60	2039.250.30
280	3.2	30	60 •	KNL	2039.280.30
300	3.2	30	72 •	2/10/60	2039.300.30
303	3.2	30	60	KNL	2139.303.31
303	3.2	30	72	KNL	2139.303.32
303	3.2	30	96	KNL	2139.303.33
305	3.2	30	60 •	2/10/60	2039.305.30
305	3.2	30	96 •	2/10/60	2039.301.30
350	3.5	30	84 •	2/10/60	2039.350.31
350	3.5	30	108 •	2/10/60	2039.350.30

• = Supplied with copper plugs  
 = Supplied in "Piano Plus" (low noise) version  
 KNL = Supplied with combination pinholes (2/10/60 and 2/7/42)

## 40° High Angle ATB Saw Blades

### 2195

40° high ATB grind for producing chip free cuts on double sided materials without scoring. All sizes supplied in "Piano Plus" (low noise) version.

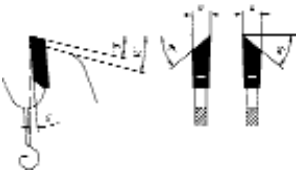

D	B	d	Z		Part No.
160	3.0	20	54	2/6/32	2195.160.21
190	3.0	30	60		2195.190.31
216	2.9	30	60		2195.216.31
220	3.2	30	68	KNL	2195.220.31
225	2.8	30	68		2195.225.31
250	3.2	30	76	CNL	2195.250.31
280	3.2	30	78		2195.280.31
303	3.2	30	90	CNL	2195.303.31
350	3.5	30	96	CNL	2195.350.31

= Supplied in "Piano Plus" (low noise) version  
 KNL = Supplied with combination pinholes (2/10/60 and 2/7/42)  
 CNL = Supplied with pinholes (2/7/42+2/9/46.4+2/10/60)

\*See inch dimension section for 30° high angle saw blades.

# Panel Sizing Saw Blades – Alternate Top Bevel

**GUHDO®**

For use on horizontal beam saws with scoring. Recommended for cutting single or multiple sheets. Use the ATB when cutting hardboard and veneered materials.

**2050**

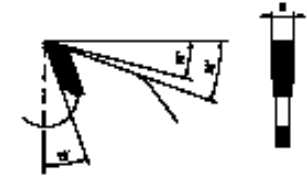

D	B	b	d		Z	For Machine	Part No.	
280	3.2	2.2	30	KNL	68	Panhans Euro 5	2023.280.30	
300	3.2	2.2	30	KNL	60	Scheer FM 16, FM 20	2022.300.30	
			30	CNL	72	↻	Scheer FM 16, FM 20	2123.300.31
			30	CNL	96	↻	Scheer FM 16, FM 20	2124.300.31
305	4.4	3.0	30		54	•	Mayer, Panhans	2050.305.30
			60		54	•		2050.305.60
			75		54	•	Homag Espana	2050.305.75
			80	4/9/100 + 2/14/110	54	•	SCM	2050.305.80
350	4.4	3.0	30	2/10/60	54	•	Panhans, SCM, Schreer	2050.350.30
			30	2/10/60	72	•	Panhans, Schelling, SCM	2050.350.31
			60		72	•		2050.350.61
355	4.4	3.0	75	4/15/105	54	•	Giben	2050.355.75
			30		72	•	Panhans, SCM	2050.355.31
			80	4/9/100 + 2/14/110	72	•	S.M.A., Gabbiani, SCM	2050.355.81
400	4.4	3.0	30		60	•	Mayer, Schelling	2050.400.30
			75	4/15/105	60	•	Giben, Homag Espana	2050.400.75
			30		72	•	Mayer, Schelling	2050.400.31
			80	2/9/130 + 4/19/120	72	•	Selco, S.M.A.	2050.400.81
430	4.4	3.0	80	2/9/130 + 4/19/120	60	•	S.M.A., Selco	2050.430.80
			80	2/9/130 + 4/19/120	72	•	S.M.A., Selco	2050.430.81
450	4.4	3.0	30	2/9/60	72	•	Panhans, Schelling	2050.450.31
			80	2/9/130 + 4/19/120	72	•	S.M.A., Selco	2050.450.81
500	4.4	3.0	30		72	•	Schelling, Irion	2050.500.31
			80		72	•	S.M.A.	2050.500.82
550	5.2	3.6	80		60	•	S.M.A.	2050.550.82
600	5.2	3.6	80		60	•	S.M.A.	2050.600.80

• Supplied with copper plugs

↻ Supplied in "Piano Plus" (low noise) version

Series No. 2050.400.31 and diameters 450, 500, 550 + 600 supplied with cooling slots.



## 2052

For use on horizontal beam saws with scoring. Recommended for cutting single or multiple sheets. Use the triple chip when cutting melamine and laminated materials.

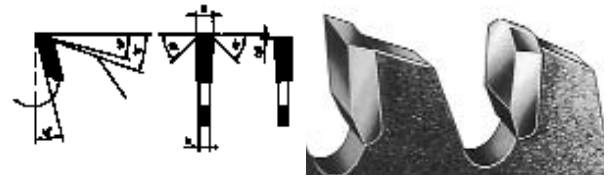

D	B	b	d		Z	For Machine	Part No.		
240	3.2	2.2	30	2/7/42	54 •	Scheer FM 10	2039.240.30		
280	3.2	2.2	30	KNL	60 •	Panhans Euro 5	2039.280.30		
280	4.4	3.2	30		60 •	Panhans Euro 5	2052.280.30		
300	4.4	3.4	75		60 •	Homag Espana	2052.300.75		
			80	2/14/110	60 •	SCM	2052.300.80		
300	4.4	3.4	75		72 •	Homag Espana	2052.300.76		
			65	2/9/110	72 •	Selco EB70	2052.300.65		
			80	2/14/110	72 •	SCM	2052.300.81		
			303	3.2	2.2	30	KNL	60 ◡	Scheer
303			30	KNL	72 ◡	Scheer	2139.303.32		
			30	KNL	96 ◡	Scheer	2139.303.33		
			305	3.2	2.2	30	2/10/60	60 •	Scheer FM 16, FM 20
305	4.0	2.8	30		60 •		2052.305.32		
			4.4	3.2	30		60 •	Mayer, Panhans,SCM	2052.305.31
350	4.4	3.2	30	2/10/60	54 •	Panhans, SCM	2052.350.31		
			75		54 •	Giben, Homag Espana	2052.350.76		
			80	Multiple	54 •	Gabbiani, SCM	2052.350.81		
			30	2/10/60	72 •	Mayer, Panhans, SCM, Schelling	2052.350.30		
			60	2/14/100	72 •	Holzma HPP72	2052.350.60		
			75		72 •	Giben, Homag Espana	2052.350.75		
			1-1/4		72 •	SCM	2052.351.30		
			80	Multiple	72 •	SCM, Gabbiani, Selco	2052.350.80		
370	4.4	3.2	30	2/10/60	72TT •	Schelling FM	2052.370.30		
380	4.4	3.2	60		72 •	Holzma	2052.380.61		
			4.8	3.5	60	2/14/100	72 •	Holzma	2052.380.60
					60	2/14/100	84TT •	Holzma	2052.380.62
					60	2/14/100	72 ◡	Holzma	2152.380.62
400	4.4	3.0	75		72 •	HolzHerAcurra B&S, Logica, CA80	2052.380.75		
			4.25	3.2	30		72 •	Scheer-Postforming, Schelling	2052.401.30
	4.4	3.2	30		72 ◡	Scheer-Postforming, Schelling	2152.401.31		
			30		72 •	Scheer FM14, Schelling FW, AW	2052.400.30		
			30		72 ◡	Scheer FM14, Schelling FW, AW	2152.400.31		
			30		72 •	Schelling, Meyer	2052.400.32		
			60		72 •	Holzher Optima	2052.400.60		
			75	4/15/105	72 •	Giben,Prismatic101,Homag Espana	2052.400.75		
80	Multiple	72 •	Gabbiani, SCM	2052.400.80					
80	4/19/120 + 2/9/130	72 •	S.M.A.,Selco	2052.400.81					

D	B	b	d		Z	For Machine	Part No.
420	4.8	3.5	60		72 •	Holzma	2052.421.60
			60	2/10/80	84TT •	Holzma	2052.420.60
			60		72 ◡	Holzma	2152.420.61
430	4.4	3.2	30		72 •		2052.430.30
			60	1/11/85	72 •	Anthon	2052.430.60
			75	4/15/105	72 •	Giben, Prismatic 201	2052.430.75
			80	2/9/130 + 4/19/120	72 •	Selco	2052.430.80
			75	4/15/105	96 •	Giben, Prismatic 201	2052.431.75
450	4.4	3.2	30	2/9/60	60 •		2052.450.31
			30	2/9/60	72 •	Panhans, Schelling, Mayer	2052.450.30
			80	2/9/130 + 4/19/120	72 •	S.M.A., Selco	2052.450.80
			80	2/14/110	72 •	Gabbiani	2052.450.82
			80	2/9/130 + 4/19/120	96 •	S.M.A., Selco	2052.450.81
450	4.8	3.5	60	2/14/125	72 •	Holzma	2052.451.60
			30		84TT •	Schelling FL Postforming	2052.450.32
460	4.4	3.2	30		72 •	Schelling	2052.460.30
470	4.4	3.0	75	4/15/105	96 •	Giben, Prismatic 301	2052.470.75
480	4.4	3.2	30		80TT •	Schelling FM	2052.480.30
500	4.4	3.2	30		60 •	Schelling	2052.500.31
	4.4	3.2	80		60 •	S.M.A.	2052.500.79
	4.8	3.5	60	1/11/85 + 2/11/115	60 •	Anthon, Holzma	2052.500.60
	4.8	3.5	60	2/11/115	72 •	Holzma	2052.500.61
520	4.8	3.5	60	2/11/115 + 2/19/120	60 •	Holzma	2052.520.60
550	5.0	3.5	80		60 •	S.M.A.	2052.550.80
	5.2	3.5	40		72 •	Schelling AT, FT	2052.550.40
	5.0	3.5	100		72 •	Giben	2052.550.10
565	5.0	3.5	100		72 •	Giben	2052.565.10
570	4.8	3.5	60		60 •	Holzma	2052.570.60
600	5.8	4.0	60	2/11/115 + 2/19/120	60 •	Holzma	2052.600.61
	5.8	4.1	60	2/11/115 + 2/19/120	72 •	Holzma	2052.600.60
700	6.0	4.4	80	1/17/110	60 •	Anthon	2052.700.80

TT = Supplied with uni-chip grind      KNL = Supplied with combination pinholes (2/10/60 + 2/7/42)  
 • = Supplied with copper plugs      ◡ = Supplied in "Piano Plus" (low noise) version  
 Series No. 2052.400.32, 2052.421.60 and diameters 450 mm and above supplied with cooling slots

## 2055

For use on horizontal beam saws and sliding table saws.

Adjustable = V  
 Conical = K  
 Conical/ATB = KW  
 Alternate Top Bevel = W

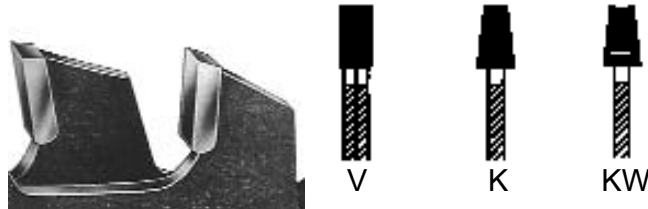

Machine	D	B	d	Z		Tooth Shape	Part No.
GEA + Felder	80	2.8-3.6	20	2 X 10		V	2055.080.20
Martin	100	2.8-3.6	22	2 X 12		V	2055.100.22
Schelling, Robland	100	2.8-3.6	20	2 X 12		V	2055.101.20
SCM	120	2.8-3.6	3/4	2 X 12		V	2055.120.75
Altendorf, Martin	120	2.8-3.6	22	2 X 12		V	2055.120.22
Martin T72A	120	2.8-3.6	22	2 X12	2x4 SL	V	2055.121.22
Holzher, SCM	120	2.8-3.6	20	2 X 12		V	2055.120.20
Holzher	180	3.0-3.8	30	2 X18		V	2055.180.30
SCM	150	3.0-3.8	30	20 X 2		V	2055.152.30
Holzma	160	2.8-3.8	20	16 X 2		V	2055.160.20
Guhdo Ritzmatic	120	2.8-3.6	50	12 X 2	2x4 SL	V	2055.120.51
Leuco System	120	2.8-3.6	50	12 X 2	2x4 SL	V	2055.120.50
Guhdo Ritz-Fix	120	2.8-3.6	57	12 X 2	4 SL	V	2055.122.22
Guhdo Ritzmatic	125	2.8-3.6	50	12 X 2	2x4 SL	V	2055.125.51
Leuco scoring	180	3.2	60	48	3/22/80	F	2055.181.50
Schelling	100	3.0-3.7	20	20		K	2055.100.20
SCM	120	3.2-3.9	20	24		K	2055.122.20
Panhans	125	3.2-3.9	20	24		K	2055.125.20
Panhans	125	4.4-5.1	20	24		K	2055.126.20
Martin T83 - 84	125	2.8-3.5	22	24		K	2055.125.22
Giben, Mayer, Homag Espana	125	4.4-5.1	45	24		K/W	2055.125.45
Giben, Mayer	127	4.4-5.1	45	24		K	2055.127.45
Scheer F M 9,15	140	3.2-3.9	16	32	1/6/33	K/W	2055.140.16
SCM	150	4.4-5.1	1-1/4	24		K	2055.150.31
Mayer-Lombach PS-2	150	4.4-5.1	30	24		K	2055.150.30
Homag Espana	150	4.4-5.1	45	24		K/W	2055.150.45
S.M.A.	160	4.4-5.1	40	28		K	2055.160.40
Gabbiani,SCM	160	4.4-5.1	55	36	2/14/110 & 3/7/66	K/W	2055.160.55
Giben Prismatic 101	160	4.4-5.1	45	28	3/11/70	K/W	2055.160.45
Scheer FM 10, 11, 12	180	3.2-3.9	16	42	1/6/33	K	2055.180.16
Anthon, Schelling	180	4.4-5.1	20	30		K/W	2055.180.20
Panhans Euro 30, Teutomatic	180	4.4-5.1	30	30		K/W	2055.180.31
Homag Espana	180	4.4-5.1	45	30		K/W	2055.180.46
Holzma HPP11/L11/V11	180	4.8-5.6	45	36		K	2055.180.45
Giben	180	5.0-5.7	55	30		K/W	2055.180.55

Continued from previous page **2055**

Machine	D	B	d	Z		Tooth Shape	Part No.
Schelling FL, AL	200	4.4-5.1	20	34		K/W	2055.200.20
Scheer FM 14, S.M.A.	200	4.4-5.1	30	34	2/9/60	K	2055.200.32
Holzma, Homag Espana	200	4.4-5.1	45	36		K	2055.200.47
Scheer FM 16	200	3.2-3.8	30	60		K/W	2055.200.31
Smid, Teutomatic, M&S	200	4.0-4.7	30	34		K	2055.200.30
Holzma	200	4.6-5.3	45	34		K/W	2055.200.45
Schelling	200	4.8-5.8	20	36		K	2055.200.21
Holzma	200	5.9-6.6	45	34		K	2055.201.45
Selco WN, WNT, EB	200	4.4-5.1	65	34	2/9/110	K/W	2055.200.65
Holzma Typ 21,22, 41,81,92	200	4.8-5.5	45	36		K	2055.200.46
Schelling FS, AS, AT, FT	200	5.2-6.4	20	36		K/W	2055.200.22
Teutomatic	200	5.2-6.4	30	36		K	2055.200.33
S.M.A.	200	5.2-6.4	40	36		K	2055.200.40
Gabbiani, SCM	200	4.4-5.1	80	36	2/14/110	K	2055.200.80
Giben Prismatic 201&203	215	4.4-5.1	50	42	3/15/80	K/W	2055.215.50
Selco	300	4.4-5.1	65	48		K/W	2055.300.65

Saw Blades for Postforming (ATB Grind)

Holzma Typ 11	200	5.0	45	60		W	2055.200.48
Schelling FL Postforming	220	4.9	20	48 •		W	2055.220.20
Homag Espana Postforming	250	4.48	45	80 •		W	2055.250.45
Holzma Typ 11, 81, 22, 33, 92	340	5.0	45	108 •	3/14/65	W	2055.342.45

D = 180 & up supplied with copper plugs



# Ritzmatic Scoring Unit

**5055**

A system that offers precise adjustment of scoring saws without spacers. Adjustment is achieved by the use of a wrench.

For machines:

Altendorf 2120 & 2220, Casolin Astra Top Digit, Lazzari & Felder

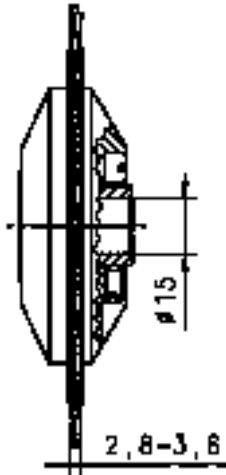

	Part Number
GUHDO system (without scoring blade) d=15mm	5055.000.15
120 x 2.8-3.6 x 50 Z=2x12      scoring blade for GUHDO system	2055.120.51
120 x 2.8-3.6 x 50 Z=2x12      scoring blade for Leuco system	2055.120.50
125 x 2.8-3.6 x 50 Z=2x12      scoring blade for Casolin, Casadei & Lazzari	2055.125.51

**5055**

# Ritz - Fix Scoring Unit

A system that offers precise adjustment of scoring saws without spacers.

For use on the following machines,

Altendorf - before 1/95

Martin T73 - after 7/01

SCM



Advantages:

- Adjustability without spacers
- reduced set-up time
- easy to handle

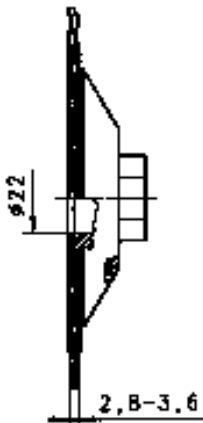

	Part Number
System for Aldendorf (without scoring blade) for 22 mm arbor (includes M20 nut)	5055.000.22
System for SCM (without scoring blade) for 3/4" arbor (includes M18 nut)	5055.000.34
System for Martin T73 (without scoring blade) for 22 mm arbor (includes M16 nut)	5055.001.22
120 x 2.8-3.6 x 57 Z=2x12 scoring blade	2055.122.22

# Table To Determine Main & Scoring By Machine Brand



For Machine	Main Blade						Scoring/Postforming Blade					
	D Ø	B	d Ø	Z	Form	Part No.	D Ø	B	d Ø	Z	Form	Part No.
Anthon LNA	380	4.4	60	72	TF	2052.380.61	180	4.4-5.1	20	30	K/W	2055.180.20
Anthon CP	430	4.4	60	72	TF	2052.430.60	180	4.4-5.1	20	30	K/W	2055.180.20
Gabbiani	400	4.4	80	72	TF	2052.400.81	180	4.4-5.1	55	36	K/W	2055.160.55
Giben, Trend	350	4.4	75	54	TF	2052.350.76	125	4.4-5.1	45	24	K/W	2055.125.45
	355	4.4	75	54	W	2050.355.75	125	4.4-5.1	45	24	K/W	2055.125.45
Giben	350	4.4	75	72	TF	2052.350.75	125	4.4-5.1	45	24	K/W	2055.125.45
Giben, Prismatic 1	400	4.4	75	72	TF	2052.400.75	160	4.4-5.1	45	28	K/W	2055.160.45
	400	4.4	75	60	W	2050.400.75	160	4.4-5.1	45	28	K/W	2055.160.45
Giben, 2000	400	4.4	75	72	TF	2052.400.75	125	4.4-5.1	45	24	K/W	2055.125.45
Giben, Prismatic 2	430	4.4	75	96	TF	2052.431.75	215	4.4-5.1	50	42	K/W	2055.215.50
Giben, Prismatic 3	470	4.4	75	96	TF	2052.470.75	215	4.4-5.1	50	42	K/W	2055.215.50
Holzma	380	4.4	80	72	TF	2052.380.61	200	4.4-5.1	45	36	K	2055.200.47
	380	4.8	60	72	TF	2152.380.62	200	4.8-5.5	45	36	K	2055.200.46
Holzma Kurztakt	380	4.8	60	72	TF	2052.380.60	340	5.0	45	108	W	2055.342.45
Holzma HPP81, HPL81,HCL81	380	4.8	60	84	TT	2052.380.62	200	4.8-5.5	45	36	K	2055.200.46
	380	4.8	60	84	TT	2052.380.62	340	5.0	45	108	W	2055.342.45
Holzma	420	4.8	60	72	TF	2052.421.60	200	4.8-5.5	45	36	K	2055.200.46
	420	4.8	60	72	TF	2152.420.61	200	4.8-5.5	45	36	K	2055.200.46
Holzma Typ 92, Typ 02	420	4.8	60	84	TT	2052.420.60	200	4.8-5.5	45	36	K	2055.200.46
	420	4.8	60	84	TT	2052.420.60	340	5.0	45	108	W	2055.342.45
Holzma HPP1/L11V11	450	4.8	60	72	TT	2052.451.60	180	4.8-5.6	45	36	K	2055.180.45
	450	4.8	60	72	TT	2052.451.60	200	5.0	45	60	W	2055.200.48
Holzma HPP21, HFL21	500	4.8	60	60	TF	2052.500.60	200	4.8-5.5	45	36	K	2055.200.46
Holzma Typ 22	500	4.8	60	72	TT	2052.500.61	200	4.8-5.5	45	36	K	2055.200.46
Holzma HPP41	520	4.8	60	60	TF	2052.520.60	200	4.8-5.5	45	36	K	2055.200.46
Holzma HPP42, HFL42	570	4.8	60	60	TF	2052.570.60	200	4.8-5.5	45	36	K	2055.200.46
Homag Espana CH 03	300	4.4	75	60	TF	2052.300.75	125	4.4-5.1	45	24	K/W	2055.125.45
	300	4.4	75	72	TF	2052.300.76	125	4.4-5.1	45	24	K/W	2055.125.45
Homag Espana CH 04/06/10	300	4.4	75	60	TF	2052.300.75	150	4.4-5.1	45	24	K/W	2055.150.45
	300	4.4	75	72	TF	2052.300.76	150	4.4-5.1	45	24	K/W	2055.150.45
Homag Espana CH 12	400	4.4	75	72	TF	2052.400.75	150	4.4-5.1	45	24	K/W	2055.150.45
	400	4.4	75	60	W	2050.400.75	150	4.4-5.1	45	24	K/W	2055.150.45
Homag Postforming	300	4.4	75	60	TF	2052.300.75	250	4.48	45	80	W	2055.250.45
Irion	400	4.4	30	72	TF	2052.400.30	150	4.4-5.1	30	24	K	2055.150.30
Mayer-Lombach PS 3+7	305	4.4	30	60	TF	2052.305.32	127	4.4-5.1	45	24	K	2055.127.45
	305	4.4	30	54	W	2050.305.30	127	4.4-5.1	45	24	K	2055.127.45
Mayer PS 3Z, PS 9Z	350	4.4	30	72	TF	2052.350.30	127	4.4-5.1	45	24	K	2055.127.45
	350	4.4	30	54	W	2050.350.30	127	4.4-5.1	45	24	K	2055.127.45
	350	4.4	30	72	W	2050.350.31	127	4.4-5.1	45	24	K	2055.127.45
Mayer Postforming	350	4.4	30	72	TF	2052.350.30	350	4.4	30	72	TF	2052.350.30
Mayer PS2	400	4.4	30	60	W	2050.400.30	150	4.4-5.1	30	24	K	2055.150.30
	400	4.4	30	72	TF	2052.400.30	150	4.4-5.1	30	24	K	2055.150.30
	450	4.4	30	60	TF	2052.450.31	150	4.4-5.1	30	24	K	2055.150.30
	450	4.4	30	72	TF	2052.450.30	150	4.4-5.1	30	24	K	2055.150.30
	450	4.4	30	72	W	2050.450.31	150	4.4-5.1	30	24	K	2055.150.30
Panhans 693 Euro 5	280	3.2	30	60	TF	2039.280.30	125	3.2-3.9	20	24	K	2055.125.20
	280	3.2	30	68	W	2023.280.30	125	3.2-3.9	20	24	K	2055.125.20
	280	4.4	30	60	TF	2052.280.30	125	4.4-5.1	20	24	K	2055.126.20
Panhans 693 Euro 10	305	3.2	30	60	TF	2309.305.30	125	3.2-3.9	20	24	K	2055.125.20
	305	4.4	30	60	TF	2052.305.31	125	4.4-5.1	20	24	K	2055.126.20
	305	4.4	30	54	W	2050.305.30	180	4.4-5.1	30	30	K/W	2055.180.31
Panhans 693 Euro 30	350	4.4	30	54	TF	2052.350.31	125	4.4-5.1	20	24	K	2055.126.20
	350	4.4	30	54	W	2050.350.30	125	4.4-5.1	20	24	K	2055.126.20
	350	4.4	30	72	TF	2052.350.30	125	4.4-5.1	20	24	K	2055.126.20
	350	4.4	30	72	W	2050.350.31	125	4.4-5.1	20	24	K	2055.126.20
Panhans SH 110	450	4.4	30	72	TF	2052.450.30	125	4.4-5.1	20	24	K	2055.126.20
Scheer FM 10/11/12	240	3.2	30	54	TF	2039.240.30	180	3.2-3.9	16	42	K	2055.180.16
Scheer FM 16	303	3.2	30	60	TF	2139.303.31	200	3.2-3.8	30	60	K/W	2055.200.31
	300	3.2	30	60	W	2022.300.30	200	3.2-3.8	30	60	K/W	2055.200.31
Scheer FM 16, FM 20	305	3.2	30	60	TF	2039.305.30	200	3.2-3.8	30	60	K/W	2055.200.31
	300	3.2	30	72	W	2123.300.31	200	3.2-3.8	30	60	K/W	2055.200.31
	303	3.2	30	72	TF	2139.303.32	200	3.2-3.8	30	60	K/W	2055.200.31
	300	3.2	30	96	W	2124.300.31	200	3.2-3.8	30	60	K/W	2055.200.31
	303	3.2	30	96	TF	2139.303.33	200	3.2-3.8	30	60	K/W	2055.200.31

For Machine	Main Blade						Scoring/Postforming Blade					
	D Ø	B	d Ø	Z	Form	Part No.	D Ø	B	d Ø	Z	Form	Part No.
Scheer FM 14	400	4.4	30	72	TF	2052.400.30	200	4.4-5.1	30	34	K	2055.200.32
	400	4.4	30	72	TF	2152.400.31	200	4.4-5.1	30	34	K	2055.200.32
	400	4.4	30	60	W	2050.400.30	200	4.4-5.1	30	34	K	2055.200.32
	400	4.4	30	72	W	2050.400.31	200	4.4-5.1	30	34	K	2055.200.31
Scheer FM 14 Postforming	400	4.4	30	72	TF	2052.400.30	400	4.25	30	72	TF	2052.401.31
Scheer FM 14 Postforming	400	4.4	30	72	TF	2152.400.31	400	4.25	30	72	TF	2152.401.31
Schelling FM, FI	350	4.4	30	72	TF	2052.350.30	180	4.4-5.1	20	30	K/W	2055.180.20
	350	4.4	30	72	W	2050.350.31	200	4.4-5.1	20	34	K/W	2055.200.20
Schelling FM	370	4.4	30	72	TF	2052.370.30	200	4.4-5.1	20	34	K/W	2055.200.20
Schelling FW, AW	400	4.4	30	60	W	2050.400.30	180	4.4-5.1	20	30	K/W	2055.180.20
	400	4.4	30	72	TF	2052.400.30	180	4.4-5.1	20	30	K/W	2055.180.20
	400	4.4	30	72	TF	2152.400.31	180	4.4-5.1	20	30	K/W	2055.180.20
	400	4.4	30	72	W	2050.400.31	180	4.4-5.1	20	30	K/W	2055.180.20
Schelling FL, AL	450	4.4	30	72	TF	2052.450.30	200	4.4-5.1	20	34	K/W	2055.200.20
	450	4.4	30	72	W	2050.450.31	200	4.4-5.1	20	34	K/W	2055.200.20
Schelling FL Postformingsatz	450	4.8	30	84	TT	2052.450.32	200	4.8-5.8	20	36	K	2055.200.21
	450	4.8	30	84	TT	2052.450.32	220	4.9	20	48	W	2055.220.20
Schelling FL, AL	460	4.4	30	72	TF	2052.460.30	200	4.4-5.1	20	34	K/W	2055.200.20
Schelling FL	480	4.4	30	72	TT	2050.480.30	200	4.4-5.1	20	34	K/W	2055.200.20
Schelling	500	4.4	30	60	TF	2052.500.31	200	4.4-5.1	20	34	K/W	2055.200.20
	500	4.4	30	72	W	2050.500.31	200	4.4-5.1	20	34	K/W	2055.200.20
Schelling AT, FT	550	5.2	40	72	TF	2052.550.40	200	5.2-6.4	20	36	K	2055.200.22
SCM SI 150, SI 320	300	3.2	30	72	TF	2039.300.30	100	3.0-3.7	20	20	K	2055.100.20
SCM SI 16	303	3.2	30	96	TF	2139.303.33	120	3.2-3.9	20	24	K	2055.122.20
SCM	305	4.0	30	60	TF	2052.305.32	120	3.2-4.5	20	2x12	V	2055.121.20
SCM	350	4.4	30	72	TF	2052.350.30	120	3.4-4.5	20	2x212	V	2055.121.20
Selco WN, WNT, EB	400	4.4	80	72	TF	2052.400.81	200	4.4-5.1	65	34	K/W	2055.200.65
	400	4.4	80	72	W	2050.400.81	200	4.4-5.1	65	34	K/W	2055.200.65
Selco WN, WNT	430	4.4	80	72	TF	2052.430.80	200	4.4-5.1	65	34	K/W	2055.200.65
	430	4.4	80	60	W	2050.430.80	200	4.4-5.1	65	34	K/W	2055.200.65
	430	4.4	80	72	W	2050.430.81	200	4.4-5.1	65	34	K/W	2055.200.65
Selco WN, WNT	450	4.4	80	72	TF	2052.450.80	200	4.4-5.1	65	34	K/W	2055.200.65
	450	4.4	80	72	W	2050.450.81	200	4.4-5.1	65	34	K/W	2055.200.65
	450	4.4	80	96	TF	2052.450.81	200	4.4-5.1	65	34	K/W	2055.200.65
S.M.A., Schwabedissen	355	4.4	80	72	W	2050.355.81	160	4.4-5.1	40	28	K	2055.160.40
	400	4.4	80	72	TF	2052.400.81	160	4.4-5.1	40	28	K	2055.160.40
	400	4.4	80	72	W	2050.400.81	160	4.4-5.1	40	28	K	2055.160.40
	430	4.4	80	72	TF	2052.430.80	160	4.4-5.1	40	28	K	2055.160.40
	430	4.4	80	60	W	2050.430.80	160	4.4-5.1	40	28	K	2055.160.40
	430	4.4	80	72	W	2050.430.81	160	4.4-5.1	40	28	K	2055.160.40
	450	4.4	80	72	TF	2052.450.80	160	4.4-5.1	40	28	K	2055.160.40
	450	4.4	80	72	W	2050.450.81	160	4.4-5.1	40	28	K	2055.160.40
	450	4.4	80	96	TF	2052.450.81	160	4.4-5.1	40	28	K	2055.160.40
	500	4.4	80	60	TF	2052.500.79	160	4.4-5.1	40	28	K	2055.160.40
	500	4.4	80	72	W	2050.500.82	160	4.4-5.1	40	28	K	2055.160.40
	550	5.0	80	60	TF	2052.550.80	200	5.2-6.4	40	36	K	2055.200.40
	550	5.2	80	60	W	2050.550.82	200	5.2-6.4	40	36	K	2055.200.40
	600	5.2	80	60	W	2050.600.80	200	5.2-6.4	40	36	K	2055.200.40
Teutomatic	400	4.4	80	72	TF	2052.400.81	180	4.4-5.1	30	30	K/W	2055.180.31
	400	4.4	80	60	W	2050.400.80	200	4.4-5.1	30	34	K	2055.200.32
	400	4.4	80	72	W	2050.400.81	200	4.4-5.1	30	34	K	2055.200.32
	430	4.4	80	72	TF	2052.430.80	200	4.4-5.1	30	34	K	2055.200.32
	430	4.4	80	60	W	2050.430.80	200	4.4-5.1	30	34	K	2055.200.32
	430	4.4	80	72	W	2050.430.81	200	4.4-5.1	30	34	K	2055.200.32
	450	4.4	80	72	TF	2052.450.80	200	4.4-5.1	30	34	K	2055.200.32
	450	4.4	80	72	W	2050.450.81	200	4.4-5.1	30	34	K	2055.200.32
	450	4.4	80	96	TF	2052.450.81	200	4.4-5.1	30	34	K	2055.200.32
	500	4.4	80	60	TF	2052.500.79	200	4.4-5.1	30	34	K	2055.200.32
	500	4.4	80	72	W	2050.500.82	200	4.4-5.1	30	34	K	2055.200.32
	550	5.0	80	60	TF	2052.550.80	200	5.2-6.4	30	36	K	2055.200.33
	600	5.2	80	60	W	2050.600.80	200	5.2-6.4	30	36	K	2055.200.33

# Scoring Saw Blades

**GUHDO®**

For use on double end tenoners as scoring and cut-off saws. With square teeth.

D	B	d	Z	Part No.
180	3,2	30	30	2031.180.30
200	3,2	30	34	2031.200.30

## 2031 UF



For use on double end tenoners as scoring and cut-off saws. With square teeth.

D	B	d	Z	Part No.
150	3,2	40	30	2032.150.40
180	3,2	30	36	2032.180.30
200	3,2	30	42	2032.200.30

## 2032 GF



For use on double end tenoners as scoring and cut-off saws. With square teeth.

D	B	d	Z		Part No.
150	3,2	30	36		2033.150.30
150	3,2	40	36		2033.150.40
180	3,2	30	42		2033.180.30
180*	3,2	50	48	3/22/80	2055.181.50
200	3,2	30	48		2033.200.30

## 2033 KF



\* Replaces Leuco No 188264



# Scoring Saw Blades

## 2034 VF

For use on double end tenoners as scoring and cut-off saws. With square teeth.



D	B	d	Z	Part No.
150	3.2	40	48	2034.150.40
180	3.2	30	56	2034.180.30
200	3.2	30	64	2034.200.30

# Mounting Sleeve For Scoring Saws

## 2035

Quieter and more efficient, giving longer tool life. L.H. and R.H. sets consist of flange and cover plate and scoring saw with square teeth. For Homag and IMA Combima machines.

Sleeves for other machines available upon request

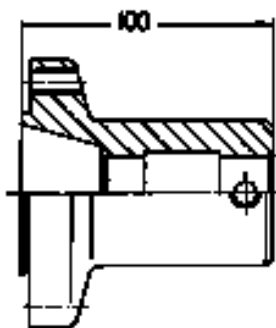

	D	B	d		Z	Part No.
Flange with screws but without saw blade.			30	DKN - 8 x 4		2035.000.3
Pack of 50 screws						2660.000.50
TCT Scoring Saw	D	B	d		Z	Part No.
L.H. side of machine	180	3,2	65	6/6.5/90	36	2035.180.65
	180	3,2	65	6/6.5/90	42	2035.182.65
	180	3,2	65	6/6.5/90	56	2035.184.65
R.H. side of machine	180	3,2	65	6/6.5/90	36	2035.181.65
	180	3,2	65	6/6.5/90	42	2035.183.65
	180	3,2	65	6/6.5/90	56	2035.185.65

# Trimming Saws For Edge Banders

**GUHDO®**

Snip Saws for Edgebanders

**2060 – 2092**

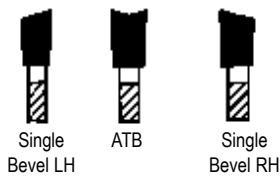

Machine	D	B	d	Z	Tooth shape	LH Part No	RH Part No.
Homag/Brandt	100	2.6	32	30	Positive Alternate Bevel	2092.100.32	2092.100.32
	100	3.0	32	20	Positive Single Bevel	2060.100.32	2060.101.32
	100	3.0	32	20	Negative Single Bevel	2060.102.32	2060.103.32
	100	3.6	32	20	Positive Alternate Bevel	2060.104.32	2060.104.32
	100/94	5.6	32	20/20	Bevel Trimming Set		
					Negative Single Bevel	2060.094.32	2060.095.32
	110	3.6	32	20	Positive Alternate Bevel	2060.110.32	2060.110.32
	110/102	5.6	32	20/20	Bevel Trimming Set		
					Negative Single Bevel	2060.110.30	2060.112.30
		120	3.2	32	24	Positive Alternate Bevel	2060.120.32
	110	3.2	40	20	Positive Single Bevel	2060.110.41	2060.110.40
	120*	3.6	40	24	Positive Alternate Bevel	2060.120.40	2060.120.40
IMA	100	3.0	22	20	Positive Single Bevel	2060.100.22	2060.101.22
	150	3.5	22	30	Positive Single Bevel	2060.150.22	2060.151.22
	150	3.5	22	30	Negative Single Bevel	2060.152.22	2060.153.22
	150	3.5	22	48	Positive Alternate Bevel	2060.154.22	2060.154.22
	160	3.5	22	48	Negative Alternate Bevel	2060.160.22	2060.160.22
Ocmac	150	3.5	20	36	Positive Single Bevel	2060.150.20	2060.151.20
Holz-Her	90	3.2	30	20	Positive Alternate Bevel	2060.090.30	2060.090.30
	110	3.6	22	20	Positive Alternate Bevel	2060.110.22	2060.110.22
	120	3.2	20	24	Positive Alternate Bevel	2060.120.20	2060.120.20
	160	2.8	30	24	Positive Alternate Bevel	2091.160.30	2091.160.30
	160	3.2	20	48	Positive Alternate Bevel	2060.162.20	2060.162.20
SCM	100	2.4	30	30	Positive Alternate Bevel	2092.100.30	2092.100.30
	125	3.2	20	40	Positive Single Bevel	2060.125.21	2060.125.20
	170	2.6	30	36	Positive Alternate Bevel	2092.170.30	2092.170.30
Stefani	150	3.5	20	36	Positive Single Bevel	2060.150.20	2060.151.20
	125	3.2	20	40	Positive Single Bevel	2060.125.21	2060.125.20
Torwegge	150	3.5	22	30	Positive Single Bevel	2060.150.22	2060.151.22
	150	3.5	22	30	Negative Single Bevel	2060.152.22	2060.153.22
	150	3.5	22	48	Positive Alternate Bevel	2060.154.22	2060.154.22
Cehisa	100	3,0	32	20	Positive Single Bevel	2060.100.32	2060.101.32
	105	2,6	32	32	Positive Alternate Bevel	2092.105.32	2092.105.32
	132	2,6	32	30	Positive Alternate Bevel	2092.132.32	2092.132.32
* Supplied with c/s Pinholes							

## 4048

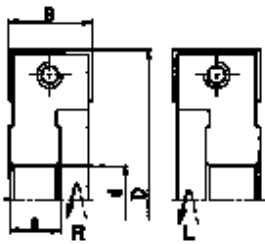
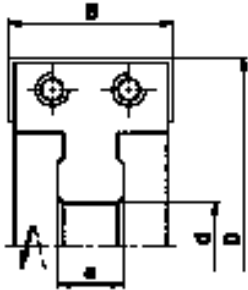

D	B	d	Z	e	Part No.	
Homag • IMA • HolzHer						
50	12	16	2	5 x 2,3	10	4048.050.12
50	15	16	2	5 x 2,3	10	4048.050.15
Brandt • Homag						
70	12	16	4	5 x 2,3	10	4048.070.12
*70	12	16	6	5 x 2,3	10	4048.071.12
70	20	16	4	5 x 2,3	11	4048.070.20
*70	20	16	6	5 x 2,3	11	4048.072.20
Stefani						
70	12	16	4	5 x 2,3	10	4048.070.12
70	20	12	6		14	4048.073.20
80	20	14	4	5 x 2,5	10	4048.080.20
Olimpic • SCM						
70	20	16	6		10	4048.074.20
70	30	16	4		12	4048.070.32
70	40	16	4		20	4048.070.40
HolzHer						
70	20	20	4		10	4048.075.20
80	40	30	4		25	4048.080.40

D	B	d	Z	e	RH Part No.	LH Part No.
Homag						
70	20	16	4	5 x 2,3 12.5	4048.071.25	4048.071.24
Brandt • Homag • IMA • IDM						
70	20	20	4	5 x 2,3 12.5	4048.071.21	4048.071.20
*70	20	20	6	6 x 3,5 12.5	4048.071.23	4048.071.22

\* denotes with double keyway

D	B	d	Z	RH Part No.	LH Part No.
Homag • IMA					
70	14.3	HSK25R	4	4048.070.14	4048.070.15
70	24	HSK25R	4	4048.070.24	4048.070.25

Solid Carbide Inserts	Part No.
12 x 12 x 1.5 for B=12	4200.012.00
15 x 12 x 1.5 for B=15	4200.015.00
20 x 12 x 1.5 for B=20	4200.020.00
30 x 12 x 1.5 for B=30	4200.030.00
40 x 12 x 1.5 for B=40	4200.040.00
14.3 x 14.3 x 2.5 for B=14.3	4200.143.14
25 x 12 x 1.5 for B=24	4200.025.01
M6x12 screw	705.533

# Radius Trimmers For Edgebanders

**GUHDO®**

## 4046

D	Dmin	B	d	Z	R	Machine	Part No.
73	61	16	16	3	2	Homag	4046.100.20
73	61	16	16	3	3	Homag	4046.100.30
73	61	16	16	3	4	Homag	4046.100.40
73	61	16	16	3	5	Homag	4046.100.50
73	61	16	20	3	2	HolzHer	4046.300.20
73	61	16	20	3	3	HolzHer	4046.300.30
73	61	16	20	3	4	HolzHer	4046.300.40
73	61	16	20	3	5	HolzHer	4046.300.50
77	70	16	16	3	3	SCM	4046.077.16
82	70	16	20	4	2	IMA	4046.200.20
82	70	16	20	4	3	IMA	4046.200.30
82	70	16	20	4	4	IMA	4046.200.40
82	70	16	20	4	5	IMA	4046.200.50

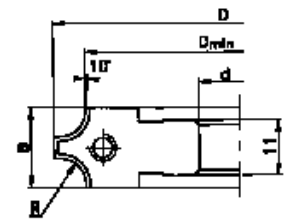
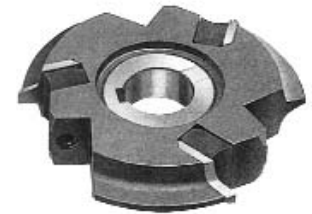

Solid Carbide Inserts	Part No.	Solid Carbide Inserts	Part No.
16 x 17.5 x 2 R=2	4107.016.02	16 x 17.5 x 2 R=5	4107.016.05
16 x 17.5 x 2 R=3	4107.016.03	*16 x 17.5 x 2 R=3	4107.147.03
16 x 17.5 x 2 R=4	4107.016.04	M6x10 screw	705.532
		* For SCM	

## Saw Blades For Non-Ferrous Metals

### 2080

Positive rake sawblade with special carbide for cutting Aluminum and plastic extrusions. Also suitable for cutting aluminum and plastic sheets. For the best finish, it is recommended that the material is firmly clamped.

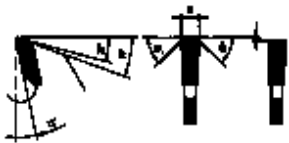
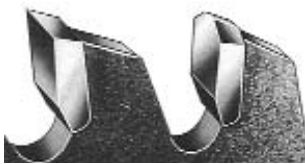

D	B	b	d		Z	for machine	Part No.
200	3,2	2,2	30		48 •	Eisele, Eumenia, Hafele	2080.200.30
215	3,2	2,2	30		60 •	Elu	2080.215.30
225	2,5	1,8	30		68 •	Festo	2080.225.30
250	3,4	2,4	30	2/10/60	40 •	Elu, Haffner, Makita, Dewalt	2080.252.30
			30	2/10/60	60 •	Elu, Haffner, Makita, Dewalt	2080.250.30
			30	2/10/60	80 •	Elu, Haffner, Makita, Dewalt	2080.251.30
280	3,2	2,2	30	KNL	68 •	AEG, Mafell	2080.280.30
300	3,8	2,8	30	2/10/60	72 •	Dewalt, Fezer, Rapid	2080.300.30
			30	2/10/60	96 •	Dewalt, Fezer, Rapid	2080.301.30
			40	4/12/64 + 2/9/55	96 •	Eisele, Ulmia	2080.300.40
330	3,4	2,4	30	2/10/60	84 •	Haffner	2080.330.30
			30	2/10/60	100 •	Haffner	2080.331.30
350	4,0	3,0	30	2/10/60	60 •	Dewalt, Haffner, Ulmia	2080.352.30
			30	2/10/60	84 •	Dewalt, Haffner, Ulmia	2080.350.30
			30	2/10/60	108 •	Dewalt, Haffner, Ulmia	2080.351.30
			40	4/12/64 + 2/9/55	84 •	Eisele	2080.350.40
			30	2/10/60	96 ◡	Dewalt, Haffner, Ulmia	2180.353.31
			30	2/10/60	90 •	Rapid, Elu	2080.370.30
370	4,2	3,2	30		96 ◡	Rapid	2080.400.30
400	4,2	3,2	30		60 •	Rapid, Dewalt, Haffner	2080.401.30
					96 •	Elu, Rapid	2080.420.30
420	4,2	3,2	30		96 •	Elu, Rapid	2080.420.30
450	4,4	3,4	40	4/12/64 + 2/12/80	110 •	Eisele	2080.450.40
500	4,6	3,6	30		100 •	Oliver, Hafnel, Rapid, Elu	2080.500.30
			30		120 •	Oliver, Rapid, Elu	2080.501.30
					• Supplied with copper plugs	◡ Supplied in "Piano Plus" (low noise) version	

# Saw Blades For Non-Ferrous Metals

**GUHDO®**

Negative rake sawblade with special carbide for cutting Aluminum and plastic extrusions.  
Also suitable for cutting aluminum and plastic sheets. For the best finish, it is recommended that the material is firmly clamped.

**2085**

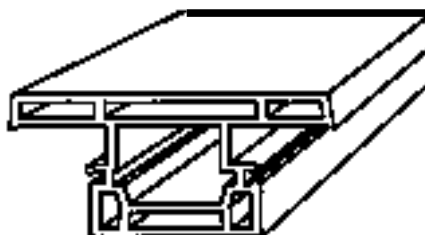
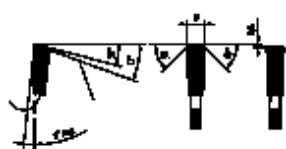

D	B	b	d		Z	for machine	Part No.
180	2.8	2.2	20		42 •		2085.180.20
			30		42 •		2085.180.30
200	2.8	2.2	30		48 •	Ulmia	2085.200.30
216	2.8	2.2	30		48 •	Elu	2085.216.30
			30		64 •	Elu	2085.217.30
220	2.8	2.2	30	KNL	80 •	Haffner, Holz-Her	2085.221.30
250	3.1	2.5	30	CNL	60 •	Elu, Haffner, Makita	2085.250.30
			30	CNL	80 •	Elu, Haffner, Makita	2085.251.30
			32		60 •	Kaltenbach	2085.250.32
			32		80 •	Elu	2085.251.32
275	3.1	2.5	40	4/12/64 + 2/9/55	60 •	Eisele, Graule	2085.250.40
			40	4/12/64 + 2/9/55	80 •	Eisele, Graule	2085.251.40
			40	4/12/64 + 2/9/55	68 •	Eisele, Graule	2085.275.40
			40	4/12/64 + 2/9/55	88 •	Eisele, Graule	2085.276.40
300	3.2	2.6	30		72 •	Dewalt, Fezer	2085.300.30
			30		96 •		2085.301.30
			32		72 •	Elu	2085.300.32
			32		96 •	Elu	2085.301.32
330	3.4	2.8	40	4/12/64 + 2/9/55	72 •	Eisele, Graule	2085.300.40
			30		84 •	Elu, Haffner	2085.330.30
			30		100 •	Elu, Haffner	2085.331.30
			32		84 •	Elu	2085.330.32
			32		100 •	Elu	2085.331.32
350	3.6	3.0	30		84 •	Haffner	2085.350.30
			30		108 •	Haffner	2085.351.30
			40	4/12/64 + 2/9/55	84 •	Eisele	2085.350.40
			40	4/12/64 + 2/9/55	108 •	Eisele	2085.351.40
			50	4/15/80	84 •	Kaltenbach	2085.350.50
			50	4/15/80	108 •	Kaltenbach	2085.351.50
350		3.5	30		72 ◡		2185.351.31

D	B	b	d		Z	for machine	Part No.
370	3,6	3,0	30		90 •	Elu	2085.370.30
			50	4/15/80	90 •	Kaltenbach	2085.370.50
380	3,6	3,0	32		108 •	Elumatec	2085.381.32
400	3,8	3,2	30		96 •	Dewalt	2085.400.30
			40	4/12/64 + 2/9/55	96 •	Eisele	2085.400.40
			50	4/15/80	66 •	Kaltenbach	2085.400.50
			50	4/15/80	96 •	Kaltenbach	2085.401.50
			40		96 •	Graule	2085.420.40
420	3,8	3,2	30		96 •	Elu, Rapid	2085.420.30
			40		96 •	Dewalt, Haffner	2085.450.30
450	4,1	3,5	30		96 •	Dewalt, Haffner	2085.450.30
			40	2/15/100 + 2/15/80	100 •	Eisele	2085.450.40
			50	4/15/80	96 •	Kaltenbach	2085.450.50
500	4,1	3,5	30		100 •	Haffner, Oliver	2085.500.30
			30		120 •	Oliver	2085.501.30
			50	4/15/80	80 •	Kaltenbach	2085.500.50
			50	4/15/80	120 •	Kaltenbach	2085.501.50

• Supplied with copper plugs      CNL = Supplied with combination pinholes (2/10/60 & 2/7/42)

## Special Saw Blades For Plastics And Panel Products

### 2286

With triple chip teeth and negative hook. The special grade of carbide in this saw permits the sizing of many materials including panels veneered with sheet metal and aluminum/plastic and some metal profiles. Nails, staples, etc. in the material do not have to be removed.

D	B	d	Z		Part No.
150	2,8	20	42	2/6/32	2286.150.20
		30	42		2286.150.30
160	2,8	30	42	2/7/42	2286.160.30
		20	42	2/6/32	2286.160.20
170	2,8	30	48	2/7/42	2286.170.30
		180	2,8	20	48
30	48			2/7/42	2286.180.30
190	2,8	20	54	2/6/32	2286.190.20
		30	54	2/7/42	2286.190.30
200	2,8	30	54	2/7/42	2286.200.30
210	2,8	30	54	2/7/42	2286.210.30
216	2,8	30	60		2286.216.30
230	2,8	30	64	2/7/42	2286.230.30
240	2,8	30	64	2/7/42	2286.240.30
250	3,2	30	80	CNL	2286.250.30

CNL = Supplied with combination pinholes (2/10/60 & 2/7/42)

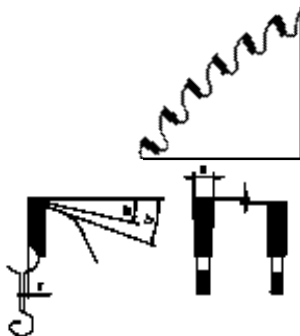

# Carbide Tipped Circular Saw Blades



These saw blades are listed according to their diameter, bore and number of teeth.  
For machines not mentioned in our list saw blades can be selected from our standard program or from this list.

## Tooth Shapes

F square for ripping  
DH pointed-hollow  
DHN pointed-hollow, negative hook, both for fine surface plastic panels  
KTH trapezoidal-hollow face for plastic faced panels  
W alternate top bevel for general purpose  
WA alternate top bevel with bossed plate for thin cuts

WFA alternate high point for mitres and cross cuts in plastic and aluminium profiles  
E single top bevel  
TF trapezoidal-square for plastic faced particle boards  
KTA trapezoidal with alternate face bevel for panels with plastic coating  
TFS trapezoidal-square negative hook for

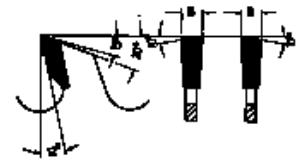

wood panels with metal and plastic/Alu profiles  
NE trapezoidal-square  
neg. positive hook for plastic/Alu profiles and plastic laminated panels  
NE pos. trapezoidal-square positive hook for plastic/Alu profiles and plastic laminated panels



D	B	d		Z	Tooth Shape	for machine	Part No.	
100	2.4	12		12	W	Elu	2090.100.12	
		12		30	W	Elu	2092.100.12	
105	2.4	20	2/5,5/30	24	W	Bosch, Festo	2091.105.20	
		20	2/5,5/30	32	W	Festo	2092.105.20	
		22		30	W	Elu, WEGOMA	2092.105.22	
110		20		24	W	Panasonic	2091.110.20	
120	2.4	20	2 NL+2 KN	24	W	Festo	2091.120.20	
		20	2 NL+2 KN	36	W	Festo	2093.120.20	
125	2.4	20	2 KN 3X5	24	W	Haffner, Mafel	2091.125.20	
		20	2 KN 3X5	36	W	Haffner, Mafell	2093.125.20	
132	2.4	20		30	W	AEG, Holz-Her	2092.132.20	
136	1.65	10		16	W	Elu	2090.136.10	
140	2.4	20	2/6/32	24	W	AEG, Bosch, Holz-Her	2091.140.20	
		20	2/6/32	42	W	AEG, Bosch, Holz-Her	2094.140.20	
150	2.6	16	1/6/33	24	W	Bosch, Scheer	2091.150.16	
		20	2/6/32	24	W		2091.150.20	
		20	2/6/32	36	W	AEG, Hitachi, Elu, Metabo, Scheer,WEGOMA	2093.150.20	
		20	2/6/32	48	W		2094.150.20	
		2.8	20	2/6/32	42 •	TFS		2089.150.20
2.6	30			18	W	Elu, Festo	2020.150.30	
	30			24	W	Elu, Festo	2021.150.30	
	30			36	W	Elu, Festo	2023.150.30	
	30			48	W	Elu, Festo	2024.150.30	
	2.8	30			42 •	TFS	Elu, Festo	2089.150.30



Continued from previous page

D	B	d		Z	Tooth Shape	for machine	Part No.
160	2.6	16	1/6/33	24	W	Black & Decker, Bosch, Scheer, Skil	2091.160.16
		16	1/6/33	36	W		2093.160.16
		16	1/6/33	48	W		2094.160.16
	2.8	16	1/6/33	42 •	TFS	Scheer	2089.160.16
	1.8	16	1/6/33	48	WA	Scheer	2096.160.16
	2.9	20	2/6/32	36 •	KTH		2041.160.20
	2.6	20	2/6/32	24	W	AEG, Festo, Hitachi, Holz-Her, Mafell. Scheer	2091.160.20
		20	2/6/32	36	W		2093.160.20
		20	2/6/32	48	W		2094.160.20
		2.8	20	2/6/32	42 •		TFS
	2.6	30	2/7/42	24	W	Festo	2091.160.30
		30	2/7/42	48	W	Festo	2094.160.30
Easy Cut	2.6	20	2/6/32	12	W		2090.160.20
High Cut	3.0	20	2/6/32	54 35°	W		2195.160.21
165	2.6	20		24	W	Makita, Metabo	2091.165.20
170	2.6	30	2/7/42	22	W	Bosch, Elu, Festo, Haffner, Hitachi, Holz-Her	2091.170.30
		30	2/7/42	36	W		2092.170.30
		30	2/7/42	52	W		2094.170.30
	3.0	30		50 •	NE pos.	Bosch, Elu, Festo, Haffner, Hitachi, Holz-Her	2080.170.30
	2.8	30	2/7/42	48 •	TFS	Bosch, Elu, Festo, Haffner, Hitachi, Holz-Her	2089.170.30
	2.0	30	2/7/42	56	TF	Festo	2095.170.30
180	2.6	16	1/6/33	22	W	Black&Decker,Scheer,Skil	2090.180.16
		16	1/6/33	48	W		2093.180.16
		16	1/6/33	56	W		2094.180.16
	2.8	16	1/6/33	48 •	TFS	Black&Decker,Scheer,Skil	2089.180.16
	1.8	16	1/6/33	56	WA	Scheer,FM	2096.180.16
	2.6	20	2/6/32	22	W	Haffner	2090.180.20
		20	2/6/32	56	W	Haffner	2094.180.20
	2.0	20	4/10,5/40	40	W	Makita	left 2095.180.20
		20	4/10,5/40	40	W	Makita	right 2095.181.20
	2.8	30	2/7/42	48 •	TFS	Scheer	2089.180.30
	2.9	30		36 •	KTH		2041.180.30
	2.6	30	2/7/42	22	W		2020.180.30
2.6	30	2/7/42	36	W		2022.180.30	
2.6	30	2/7/42	56	W		2024.180.30	
185	2.6	13	4/13,5/39	36	W	Hitachi	left 2092.185.13
							right 2092.186.13
	2.6	20		24	W	Makita	2090.185.20
		20		48	W	Makita	2094.185.20

Continued from previous page

D	B	d		Z	Tooth Shape	for machine	Part No.	
190	2.8	20	2/6/32	24	W	Kress, Metabo	2090.190.20	
		20	2/6/32	48	W	Kress, Metabo	2094.190.20	
	2.8	20	2/6/32	56 •	TFS	Kress, Metabo	2089.190.20	
	2.8	30	2/7/42	24	W	AEG, Bosch,	2090.190.30	
		30	2/7/42	48	W	Elu, Mafell, Skil	2094.190.30	
	2.8	30	2/7/42	56 •	TFS	Holz-Her, Hitachi,	2089.190.30	
2.9	30	2/7/42	42	KTH	AEG, Bosch, Skil, Festo, Mafell, Elu, Holz-Her, Hitachi	2041.190.30		
Easy Cut	2.8	30		12	W		2090.191.30	
High Cut	3.0	30		60 35°	W		2195.190.31	
200	2.8	16		64	W	Black & Decker	2094.200.16	
		18		64	W	Fezer, Stayer	2094.200.18	
		30	2/7/42	24	W		2020.200.30	
		30	2/7/42	34	W	AEG, Bosch, Festo	2021.200.30	
		30	2/7/42	48	W	Mafell, Holz-Her	2023.200.30	
		30	2/7/42	64	W	Scheer	2024.200.30	
	3.2	30		48 •	NE pos.		2080.200.30	
	2.8	30	2/7/42	60 •	TFS		2089.200.30	
	210	2.8	30	2/7/42	24	W	AEG, Bosch, Fein, Haffner Holz-Her, Hitachi, Mafell, Skil	2090.210.30
			30	2/7/42	48	W	AEG, Bosch, Fein, Haffner Holz-Her, Hitachi, Mafell, Skil	2093.210.30
		30	2/7/42	64	W	AEG, Bosch, Fein, Haffner Holz-Her, Hitachi, Mafell, Skil	2094.210.30	
		30	2/7/42	60 •	TFS	AEG, Bosch, Fein, Haffner, Hitachi, Mafell, Skil	2089.210.30	
215	2.8	30		24	W	Elu	2091.215.30	
		30		48	W	Elu	2093.215.30	
		30		64	W	Elu	2094.215.30	
	3.2	30		60 •	NE pos.	Elu	2080.215.30	
216	2.8	30		48	W neg.	Elu	2093.216.30	
	2.8	30		48 •	NE neg.	Elu	2085.216.30	
	2.8	30		64	W neg.	Elu	2094.216.30	
220	2.8	30	2/7/42	24	W	Festo, Haffner, Holz-Her	2090.220.30	
		30	2/7/42	34	W	Festo, Haffner, Holz-Her	2091.220.30	
	3.2	30	2/7/42	42 •	DH	Haffner, Holz-Her	2037.220.30	
	2.8	30	2/7/42	48 •	KTH	Haffner, Holz-Her	2041.220.30	
		30	2/7/42	64	W	Festo, Haffner, Holz-Her	2094.220.30	
	3.2	30	2/7/42	64	TF	Festo, Haffner, Holz-Her	2039.220.30	
	2.8	30	2/7/42	80 •	NE neg.	Haffner, Holz-Her	2085.221.30	
High Cut	3.2	30	KNL	68 40°	↻ W	Festo, Haffner, Holz-Her	2195.220.31	
225	2.8	30		24	W	Mafell	2090.225.30	

## Continued from previous page

D	B	d		Z	Tooth Shape	for machine	Part No.
		30		48	W	Mafell	2093.225.30
		30		68	W	Festo, Mafell	2094.225.30
230	2.5	30		68 •	NE pos.	Festo, Mafell	2080.225.30
	2.8	30	2/7/42	24	W		2090.230.30
		30	2/7/42	34	W	AEG, Bosch, Festo,	2091.230.30
		30	2/7/42	64	W	Holz-Her, Scheer, Skil	2094.230.30
	3.2	30	2/7/42	64 •	TFS		2089.230.30
235	2.1	16	4/10,5/40	40	W	Makita	left 2095.235.16
		16	4/10,5/40	40	W	Makita	right 2095.236.16
	3.0	25		24	W	Makita	2090.235.25
		25		34	W	Makita	2091.235.25
		30		24	W	Makita	2090.235.30
	3.0	25		24	W	Makita	2094.235.25
240	3.2	30	2/7/42	24	W	Bosch, Elu, Festo, Hitachi,	2003.240.30
	3.0	30	2/7/42	30	W	Holz-Her, Metabo, Robland	2090.240.30
		30	2/7/42	48	W		2092.240.30
		30	2/7/42	72	W	Bosch, Elu, Festo, Hitachi, Holz-Her	2094.240.30
	3.2	30	2/7/42	54 •	TF	Metabo, Robland, Scheer	2039.240.30
		30	2/7/42	72 •	TFS		2089.240.30
250	3.2	30	KNL	60	W	DeWalt, Elu, Festo, Haffner	2023.250.30
		30	KNL	80	W	DeWalt, Elu, Festo, Haffner	2024.250.30
		30	KNL	72 •	TFS	DeWalt, Elu, Festo, Haffner	2089.250.30
		30	KNL	24	W	Dewalt	2003.250.30
		30	KNL	30	W	Dewalt, Elu, Festo, Haffner	2020.250.30
	3.1	30	KNL	42	W	Dewalt, Elu, Festo, Haffner	2021.250.30
		30	KNL	60 •	NE neg.	DeWalt, Elu, Haffner	2085.250.30
		30	KNL	80 •	NE neg.	DeWalt, Elu, Haffner	2085.251.30
		32		60 •	NE neg.	Elu, Fezer, WEGOMA	2085.250.32
		32		80 •	NE neg.	Elu, Fezer	2085.251.32
	3.2	40	4/12/64,2/9/55	60 •	NE neg.	Graule	2085.250.40
		40	4/12/64,2/9/55	80 •	NE neg.	Graule	2085.251.40
		32		42	W	Elu	2021.250.32
		32		60	W	Elu, WEGOMA	2023.250.32
		32		80	W	Elu	2024.250.32
260	3.2	30	1/7/44	36	W	Skil	2090.260.30
	2.6	30		60	W	Makita, Skil	2093.260.30
265	2.6	13	4/13,5/39	12	F	Hitachi	left 2090.265.13
							right 2090.266.13
266	3.2	25		30	W	Makita	2090.270.25

Continued from previous page

D	B	d		Z	Tooth Shape	for machine	Part No.	
270	3.2	30		24	W	Makita	2003.270.30	
		30		48	W	Makita	2091.270.30	
		30		68	W	Makita	2093.270.30	
275	3.1	40	4/12/64,2/9/55	68 •	NE neg.	Graule	2085.275.40	
		40	4/12/64,2/9/55	88 •	NE neg.	Graule	2085.276.40	
280	3.4	30	KNL	28	W	AEG, Mafell-Erika	2003.280.30	
		3.2	30	KNL	48	W	AEG, Mafell-Erika	2021.280.30
			30	KNL	68	W	AEG, Mafell-Erika	2023.280.30
	30		KNL	68 •	NE pos.	AEG, Mafell-Erika	2080.280.30	
	2.9	30	KNL	60	TF	AEG, Mafell-Erika, Panhans	2039.280.30	
		30	KNL	68 •	KTH	AEG, Mafell-Erika, Panhans	2041.280.30	
300	3.2	30	KNL	48	W	Holz-Her	2021.300.30	
		30	KNL	72	W	Holz-Her	2023.300.30	
303	3.2	30	KNL	60 •	DH	Haffner, Holz-Her	2037.300.30	
			KNL	60 ∩	DH	Metabo, Striebig		
			KNL	60 ∩	DH	Haffner, Holz-Her, Metabo, Striebig	2137.303.31	
300	3.2	30	KNL	60 ∩	DHN	Holz-Her, Striebig	2138.303.31	
			2/10/60	72	TF	Haffner, Holz-Her	2039.300.30	
			32	72 •	NE neg.	Elu, Fezer, Haffne	2085.300.32	
305	2.8	32		96 •	NE neg.	Elu, Fezer, Haffne	2085.301.32	
		40	4/12/64,2/9/55	72 •	NE neg.	Graule	2085.300.40	
		30		60	W neg.	Elu, Scheppach	2093.305.30	
315	3.4	30	2/10/60	28	W	Elektra, Mafell, Scheppach	2003.315.30	
	3.2	30	2/10/60	48	W	Elektra, Mafell, Scheppach	2021.315.30	
		30	2/10/60	72	W	Elektra, Mafell, Scheppach	2023.315.30	
320	3.2	30	2/7/42	36	W	Mafell	2020.320.30	
		30	2/7/42	72	W	Mafell	2023.320.30	
330	3.2	30	2/10/90	100	W	Haffner	2024.330.30	
		3.4	30	2/10/60	84 •	NE pos.	Haffner	2080.330.30
	32	30	2/10/60	100 •	NE pos.	Haffner	2080.331.30	
		32		84 •	NE neg.	Elu	2085.330.32	
		32		100 •	NE neg.	Elu	2085.331.32	
335	3.2	25		30	W	Makita	2090.335.25	
		30		30	W	Hitachi	2090.335.30	

Continued from previous page

D	B	d		Z	Tooth Shape	for machine	Part No.
350	3.5	30	2/10/60	84	W	Haffner, WEGOMA	2023.350.30
		30	2/10/60	108	W	Haffner	2024.350.30
	3.6	30		84 •	NE neg.	Haffner, WEGOMA	2085.350.30
		30		108 •	NE neg.	Haffner	2085.351.30
	3.6	40	4/12/64,2/9/55	84 •	NE neg.	Graule	2085.350.40
		40	4/12/64,2/9/55	108 •	NE neg.	Graule	2085.351.40
400	4.0	30	KNL	28	F	Festo, Haffner, Mafell, Holz-Her	2002.400.30
	3.5	30	2/10/60	96	W	Haffner, WEGOMA	2023.400.30
	3.8	30		96 •	NE neg.	Haffner, WEGOMA	2085.400.30
420	4.2	30		96 •	NE pos.	Elu	2080.420.30
		30		96 •	NE neg.	Elu	2085.420.30
	40		96 •	NE neg.	Graule	2085.420.40	
450	3.8	30	4/12/64 4/12/80	100 •	NE neg.	Haffner	2085.450.30
500	3.8	30		120 •	NE	Haffner	2080.501.30
	4.6	30		100 •	NE	Elu	2085.500.30
550	4.6	30	2/7/42	48	W	Mafell	2003.550.30



# Small Hogging Set 200 mm Diameter

**GUHDO®**

Recommended RPM: n up to 8000

**2610**

Hardened and precision ground mounting sleeve  
suits any make of machine see page 46.

Hogging width 22 mm	Part No.
Teeth of trimming saw Z=42	
LH hogging set	2610.200.42
RH hogging set	2610.201.42
Teeth of trimming saw Z=60	
LH hogging set	2610.202.60
RH hogging set	2610.203.60



Hogging width 40 mm	Part No.
Teeth of trimming saw Z=42	
LH hogging set	2610.204.42
RH hogging set	2610.205.42
Teeth of trimming saw Z=60	
LH hogging set	2610.206.60
RH hogging set	2610.207.60



Hogging width 58 mm	Part No.
Teeth of trimming saw Z=42	
LH hogging set	2610.208.42
RH hogging set	2610.209.42
Teeth of trimming saw Z=60	
LH hogging set	2610.210.60
RH hogging set	2610.211.60



## Mounting Sleeve For 200mm Hogging Sets

### 2625

Hardened and precision ground with cover.  
Special locking nuts can be supplied at extra cost.

See page 32 for saw  
blades and sleeves for  
scoring units

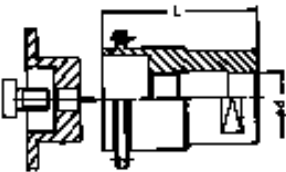
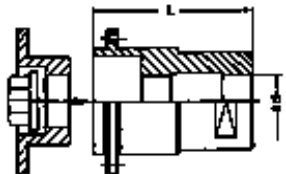
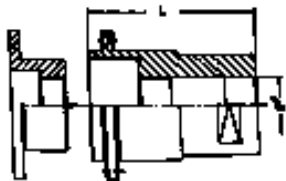

Machine	L=mm	d =mm	⊕	Part No.
B + G	91	35	10 X 4	2625.250.00
Celaschi	75	35	10 X 4	2625.251.00
Danckaert	106	35	10 X 4	2625.252.00
Festo	85	35	10 X 4	2625.253.00
Gabbiani	86	40	12 X 4	2625.254.01
	97	40	12 X 4	2625.254.02
	109	40	12 X 4	2625.254.03
	122	40	12 X 4	2625.254.04
Homag	85	35	10 X 4	2625.255.00
Hullhorst	76	35	10 X 4	2625.257.00
Kombima	102	35	10 X 4	2625.266.00
Kuhlmann	134	35	10 X 4	2625.258.00
M + S	104	40	12 X 4	2625.260.00
SCM	106	40	12 X 4	2625.260.01
Spanevello	100	35	10 X 4	2625.261.00
Torwegge, IMA	106	35	10 X 4	2625.263.00
Wadkin	80	30	8 X 4	2625.264.00
Wigo	87	35	-	2625.265.00

### Sleeves for 250mm Hogging Sets

Machine	Part No.
Homag	for hogging set 250 2625.267.00
IMA - Klessmann	for hogging set 250 2625.268.00

# Spares For 200mm Hogging Sets

**GUHDO®**

Trimming saw 205 X 4,0 X 100mm with countersunk fixing holes for GUHDO No. 2610 hogging cutterheads.

**2630**

	Tooth form	Part No.
Z=42 LH	square	2630.200.42
Z=42 RH	square	2630.201.42
Z=42 LH	single bevel	2630.202.42
Z=42 RH	single bevel	2630.203.42
Z=60 LH	square	2630.200.60
Z=60 RH	square	2630.201.60
Z=60 LH	single bevel	2630.202.60
Z=60 RH	single bevel	2630.203.60

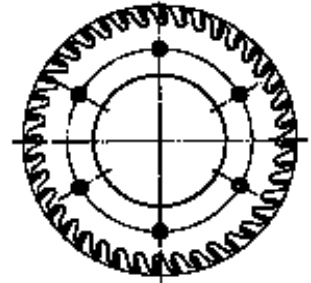

Trimming saw 200 X 4,0 X 80mm with countersunk fixing holes for LEUCO hogging cutterheads.

	Tooth form	Part No.
Z=40 LH	square	2630.200.84
Z=40 RH	square	2630.201.84
Z=60 LH	square	2630.200.86
Z=60 RH	square	2630.201.86

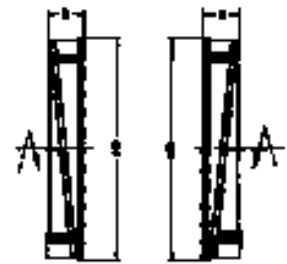

Segments for 200mm hoggers	Part No.
Z=2 x 9 LH	2630.200.09
Z=2 x 9 RH	2630.201.09



Steel cutterhead body with bolts	Part No.
LH	2630.200.00
RH	2630.201.00
Packet of 50 screws	2630.200.50

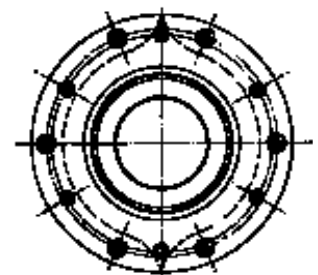



# Hogging Sets 250 – 335 mm Diameter

## 2650

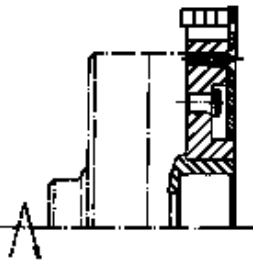
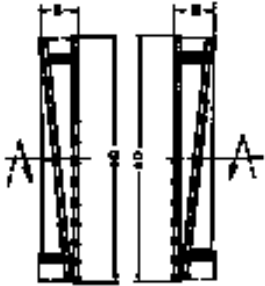

### Technical details

Body of steel with two segments and trimming saw which is precisely centered into a polished flange on the cutterhead body.

### Special features

Hoggers remove the material outwards from the cut panel edge (twice during each revolution) by the two segments being diagonally set in the cutterhead body. The cutterhead body is flush on its workpiece side with a deep recess to accept the spindle and locking nut of the machine. This means that the cutterhead can be operated very close to the chain drive of the machine and consequently cut vibration to a minimum. This also means that thicker panels can be processed with smaller diameter hogging sets, these can even be set to cut through the center of the hogger. This can be an advantage should mitering cuts be necessary by tilting the machine spindle. Another advantage of the recess in the center of the cutterhead is to reduce the weight of the body thus reducing the power requirement when starting and minimizing undue wear on the bearings of the machine. Our popular 280mm dia. hoggers give an ideal feed rate and finish to all laminated panels when running at 6000 r.p.m.

### Application

In pairs for producing a finished edge to laminated panels. Trimming saws with a high number of teeth are recommended for high feed speeds when processing panels with a delicate surface.

Recommended Max. RPM	
D=250	6,000
D=280	6,000
D=335	3,000
Hogging sets without sleeve	

D	d	Z	Segments Z	Hogging width	LH set Part no.	RH set Part No.
250	60	42	2 X 10	25	2650.250.42	2650.251.42
		60	2 X 10	25	2650.250.60	2650.251.60
	80	42	2 X 10	25	2650.252.42	2650.253.42
		60	2 X 10	25	2650.252.60	2650.253.60
280	60	42	2 X 12	30	2650.280.42	2650.281.42
		60	2 X 12	30	2650.280.60	2650.281.60
	80	42	2 X 12	30	2650.282.42	2650.283.42
		60	2 X 12	30	2650.282.60	2650.283.60
335	60	60	2 X 16	33	2650.335.60	2650.336.60
	60	60	2 X 16	45	2650.337.60	2650.338.60

## 2651 | For LEUCO Quick-Change system (with 192 mm flange)

D	d	Z	Segments Z	Hogging width	LH set Part no.	RH set Part No.
250	80	42	2 X 10	25	2651.252.42	2651.253.42
		60	2 X 10	25	2651.252.60	2651.253.60

# Spares For Large Hogging Cutterheads



## Trimming saw with countersunk fixing holes

D	B	d	Z	Tooth form	LH Part No	RH Part No.
250	4.0	130	42	F	2660.250.42	2660.251.42
			42	E	2660.252.42	2660.253.42
			60	F	2660.250.60	2660.251.60
			60	E	2660.252.60	2660.253.60
280	4.0	170	42	F	2660.280.42	2660.281.42
			42	E	2660.282.42	2660.283.42
			60	F	2660.280.60	2660.281.60
			60	E	2660.282.60	2660.283.60
335	4.0	230	60	F	2660.335.60	2660.336.60

## 2660

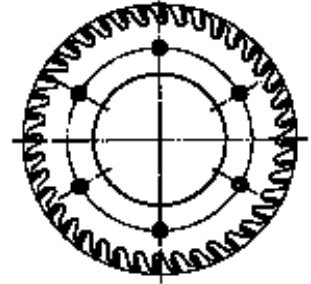

## Trimming saw for LEUCO quick change system

D	B	d	Z	Tooth form	LH Part No	RH Part No.
220	4.0	80	60	F	2660.221.60	2660.220.60
250	4.0	80	48	F	2660.250.48	2660.251.48
		100	48	F	2660.252.48	2660.253.48
250	4.0	80	72	F	2660.250.72	2660.251.72
		100	72	F	2660.252.72	2660.253.72

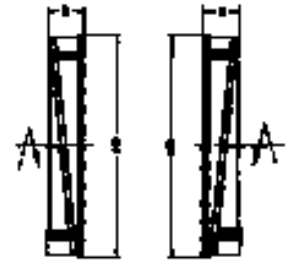

## Segments

D	Z	Part No.
245	2 X 10	2660.250.10
275	2 X 12	2660.280.12
330	2 X 16	2660.335.16
200/250*	4	2660.202.09

Tooth forms:  
F = square  
E = single bevel



\*Replaces Leuco No. 167118

## Steel cutterhead body with bolts

D	B	d	LH Part No.	RH Part No.
250	25	60	2660.250.06	2660.251.06
		80	2660.250.08	2660.251.08
280	30	60	2660.280.06	2660.281.06
		80	2660.280.08	2660.281.08
335	33	60	2660.335.33	2660.336.33
	45	60	2660.335.45	2660.336.45

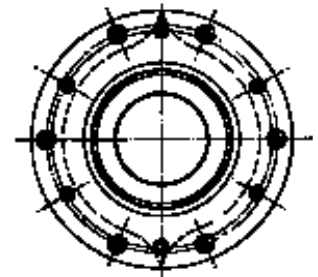

## Steel body for LEUCO quick change system

D	B	d	LH Part No.	RH Part No.
250	25	80	2661.250.08	2661.251.08
Packet of 50 screws				2660.000.50

## 3008 Z12

Other diameters, bores  
and kerfs available  
upon request

b denotes plate thickness

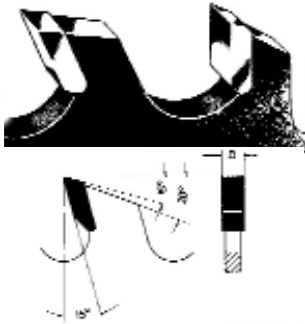

D	B	b	d	Part Number
125	1.5	2.0	30	3008.125.15
	1.8	2.0	30	3008.125.18
	2.0	2.0	30	3008.125.20
	2.2	2.0	30	3008.125.22
	2.5	2.0	30	3008.125.25
	3.0	2.0	30	3008.125.30
	3.5	2.5	30	3008.125.35
	4.0	3.0	30	3008.125.40
	4.5	3.5	30	3008.125.45
	5.0	4.0	30	3008.125.50
	6.0	5.0	30	3008.125.60
	1/4	5.0	30	3008.125.63
	7	6.0	30	3008.125.70
	8	6.0	30	3008.125.80
150	10	8.0	30	3008.125.01
	1.5	2.0	30	3008.150.15
	2.0	2.0	30	3008.150.20
	2.2	2.0	30	3008.150.22
	2.5	2.0	30	3008.150.25
	3.0	2.0	30	3008.150.30
	3.5	2.5	30	3008.150.35
	4.0	3.0	30	3008.150.40
	4.5	3.5	30	3008.150.45
	5.0	4.0	30	3008.150.50
	6.0	5.0	30	3008.150.60
	1/4	5.0	30	3008.150.63
	7.0	6.0	30	3008.150.70
	8.0	6.0	30	3008.150.80
10.0	8.0	30	3008.150.01	
180	4.0	3.0	30	3008.180.40
	5.0	4.0	30	3008.180.50
	6.0	5.0	30	3008.180.60
	8.0	6.0	30	3008.180.80
	10.0	8.0	30	3008.180.01

## 3009 Z12

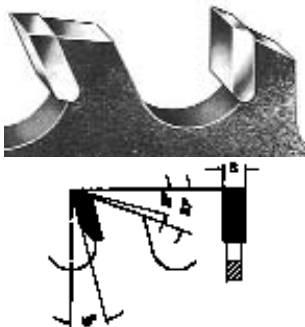

D	B	b	d	Part Number	
150	1.5	2.0	30	3009.150.15	
	2.0	2.0	30	3009.150.20	
	2.5	2.0	30	3009.150.25	
	3.0	2.0	30	3009.150.30	
	3.5	2.5	30	3009.150.35	
	4.0	3.0	30	3009.150.40	
	4.5	3.5	30	3009.150.45	
	5.0	4.0	30	3009.150.50	
	6.0	5.0	30	3009.150.60	
	7.0	6.0	30	3009.150.70	
	8.0	6.0	30	3009.150.80	
	10.0	8.0	30	3009.150.01	
	180	4.0	3.0	30	3009.180.40
		5.0	4.0	30	3009.180.50
6.0		5.0	30	3009.180.60	
8.0		6.0	30	3009.180.80	
10.0		8.0	30	3009.180.01	

# TCT Lamello Groover

**GUHDO®**

**3116 Z2+4**

D	B	d	Z+V	Part Number
100	3,98	22	2+4	3116.100.22
Mini Patch Cutter				
100	8	22	4	3116.110.22



# TCT Lamello Groover

**3120 Z4+V4**

D	B	d	Part No.
100	3.97	22	3020.100.22

Solid Carbide Inserts	Part No.
Groover 18 x 18 x 1.95	4200.018.20
Spur 14 x 14 x 1.2	4200.014.12
Torx screw	3020.000.00
Torx nut for groover	3020.000.01
Torx nut for spur	3020.000.02
Torx key T 9	3020.000.10



# TCT Adjustable Groover

Made of a two part steel body and spacers. For producing grooves in solid woods and composites.

**3123**

D	B	d	Max. groove depth	Z+V	Part No.
120	1,8-3,4	30	12	6+6	3123.018.34
120	2,2-4,0	30	15	6+6	3123.030.58
140	2,2-4,0	30	15	6+6	3123.031.58



## 4010 Z2+V2

For use on moulders with pre-straightening grooves in the bed.



Recommended RPM:  
6,000-12,000

D	B	d	Z	V	Part No.
125	9	Specify	2	2	4010.125.09
125	10	Specify	2	2	4010.125.10
125	17	Specify	2	2	4010.125.17
125	20	Specify	2	2	4010.125.20
					cutters supplied without arbor spacers

Solid Carbide Inserts	Part No.
9.6 x 12 x 1.5 for B=10	4200.096.00
8.6 x 12 x 1.5 for B=9	4200.086.00
17 x 12 x 1.5 for B=17	4200.017.00
20 x 12 x 1.5 for B=10	4200.020.00
14 x 14 x 2.0	4200.014.04

Replacement Parts	Part No.
M6x12 screw for B=9/10	705.533
M8x16 screw for B=17/20	705.542
M5x8 screw for spur	705.422
Wedge for B=9/10	707.002.08
Wedge for B=20	707.002.18
Wedge for B=17	707.002.15

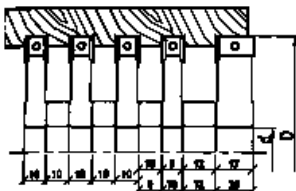

# Insert Grooving Cutterhead

**GUHDO®**

Non-adjustable insert groovers for use on shapers, tenoners, edgebanders and moulders.

**4020**

D	B	d	Z	V	Tmax	Part No.
120	4	Specify	4	4	27	4020.120.04
120	5	Specify	4	4	27	4020.120.05
120	6	Specify	4	4	27	4020.120.06
140	4	Specify	4	4	32	4020.140.04
140	5	Specify	4	4	32	4020.140.05
140	6	Specify	4	4	32	4020.140.06
140	8	Specify	4	4	32	4020.140.08
140	10	Specify	4	4	32	4020.140.10
140	12	Specify	4	4	32	4020.140.12
140	15	Specify	4	4	32	4020.140.15



Recommended RPM:

D=120      6,000 - 9,000

D=140      5,400 - 8,000

Solid Carbide Inserts	Part No.
18 x 18 x 1.95 for B=4	4200.018.20
18 x 18 x 2.45 for B=5	4200.018.25
18 x 18 x 2.95 for B=6	4200.018.30
14 x 14 x 1.2 for B=4,5&6 (spur)	4200.014.12
7.5 x 12 x 1.5 for B=8	4200.008.00
9.6 x 12 x 1.5 for B=10	4200.096.00
11.6 x 12 x 1.5 for B=12	4200.116.00
14.6 x 12 x 1.5 for B=15	4200.146.00
14 x 14 x 2.0 for B=8,10&12 (spur)	4200.014.04

## 4050

Made of a two part steel body and spacers. For producing various grooves and rebates in solid woods and composites with or without melamine, veneer and laminate.

### Recommended RPM

D=160	4,800 - 8,300
D=180	4,300 - 7,400



D	B	d	Z	V	Tmax	Part No.
160	4.0-7.5	Specify	4	4	32	4050.160.30
160	8.0-15	Specify	4	4	32	4050.161.30
160	12.5-24	Specify	4	4	32	4050.162.30
180	4.0-7.5	Specify	4	4	38	4050.180.30
180	8.0-15	Specify	4	4	38	4050.181.30
180	12.5-24	Specify	4	4	38	4050.182.30

### Solid Carbide Inserts

### Part No.

18 x 18 x 1.95	for B = 4 - 7.5	4200.018.20
7.5 x 12 x 1.5	for B = 8 - 15	4200.008.00
12 x 12 x 1.5	for B = 12.5 - 24	4200.012.00
14 x 14 x 2.0	for 8.-15 & 12.5-24(spur)	4200.014.04
14 x 14 x 1.2	for 4-7.5(spur)	4200.014.12

### Replacement Parts

### Part No.

M4x3.2 screw	for B=4-7.5	3020.000.00
M5x12 screw	for B=8-15	705.523
M8x16 screw	for B=12.5-24	705.542
M5x6 screw	for spur B=8-15	705.424
M5x8 screw	for spur B=12.5-24	705.422
Wedge	for B=8-15	707.002.06
Wedge	for B=12.5-24	707.002.10
Nut	for 18x18x1.95 insert	3020.000.01
Nut	for 14x14x1.2 spur	3020.000.02

## Insert Rebate Cutterhead

### 4030

Specially suitable for producing rebates and joints with excellent finish to chipboard, plywood, M.D.F., compressed boards and plastics together with hard and softwoods and exotic timbers with or without glue lines.



D	B	d	Z	V	Part No.
100	50	Specify	2	4	4030.100.50
100	50	Specify	4	4	4030.100.54
125	30	Specify	2	4	4030.125.30
125	30	Specify	4	4	4030.125.34
125	50	Specify	2	4	4030.125.50
125	50	Specify	4	4	4030.125.54
125	60	Specify	2	4	4030.125.60

Solid Carbide Inserts	Part No.
30 x 12 x 1.5 for B=30	4200.030.00
50 x 12 x 1.5 for B=50	4200.050.00
14 x 14 x 2.0 spur	4200.014.04
M8x16 screw	705.541
M8x16 screw for B=50 (D=125)	705.542
M5x8 screw for spur	705.422
Wedge for B=30	707.002.28
Wedge for B=50	707.002.48
Wedge for B=60	707.002.58

Recommended RPM:	
D=100	7,800 - 13,300
D=125	6,200 - 10,600
D=140	5,500 - 9,500
D=147	5,200 - 9,000

## Insert Rebate Cutterhead

### 4031

Produced with 8° alternating shear. Especially suitable for producing rebates and joints that require an excellent finish to particleboard, plywood, MDF, other compressed boards, hardwood & softwoods (with or without glue lines) and plastics.



D	B	d	Z	V	Part No.
125	50	Specify	4	4	4031.125.54
140	50	Specify	4	4	4031.140.54
147	50	Specify	4	4	4031.147.54

Solid Carbide Inserts	Part No.
50 x 12 x 1.5	4200.050.00
14 x 14 x 2.0 spur	4200.014.04
M8x16 screw	705.542
M5x8 screw for spur	705.422
Wedge RH	707.133.48
Wedge LH	707.130.48



# Adjustable Insert Rebate Cutterhead

**GUHDO®**

For producing short tenons or grooves in solid timbers or composites. Also suitable for jointing.

**4035**



D	B	d	Z	V	Part No.
160	16-30	Specify	4	4	4035.030.30
160	21-40	Specify	4	4	4035.040.30
160	31-60	Specify	4	4	4035.060.30
160	51-100	Specify	4	4	4035.100.30

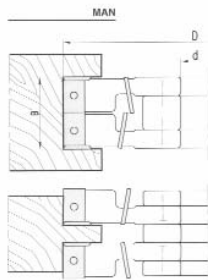

Recommended RPM:  
4,800 - 8,300

Solid Carbide Inserts	Part No.
15 x 12 x 1.5 for B=16-30	4200.015.00
20 x 12 x 1.5 for B=21-40	4200.020.00
30 x 12 x 1.5 for B=31-60	4200.030.00
50 x 12 x 1.5 for B=51-100	4200.050.00
14 x 14 x 2.0 spur	4200.014.04
M8x16 screw	705.542
M5x8 screw for Spur	705.422
Wedge for B=21-40	707.900.20
Wedge for B=31-60	707.900.30
Wedge for B=51-100	707.900.50
Wedge for B=16-30	707.900.15

# Insert Cutterhead With Shear

With up shear and down shear knives designed to produce chip free cuts on double sided materials. Non-adjustable.

**4036**



D	B	d	Z	Part Number
125	56	30 DKN	3+3	4036.125.30
125	56	40 DKN	3+3	4036.125.40
150	56	30 DKN	3+3	4036.150.50
150	56	35 DKN	3+3	4036.150.35
180	56	35 DKN	3+3	4036.180.50
180	56	40 DKN	3+3	4036.180.40

KN denotes with keyway

Recommended RPM:  
D=150 5,200 - 8,900  
D=180 4,300 - 7,400  
D=125 6,200-10,600

Solid Carbide Inserts	Part No.
30 x 12 x 1.5	4200.030.00
M8x16 screw	705.542
Wedge RH	707.133.28
Wedge LH	707.130.28

# Insert Jointing Cutterhead

**GUHDO®**

All insert cutterheads without spurs for jointing composites and solid woods.

**4041**

D	B	d	Z	Part Number
100	50	Specify	2	4041.100.50
100	50	Specify	4	4041.100.51
125	30	Specify	4	4041.125.31
125	50	Specify	4	4041.125.51
125	60	Specify	4	4041.125.61
125	80	Specify	4	4041.125.81



Solid Carbide Inserts	Part No.
30x12x1.5 for B=30	4200.030.00
50x12x1.5 for B=50	4200.050.00
60x12x1.5 for B=60	4200.060.00
80x13x2.2 for B=80	4200.080.00
M8x16 screw	705.542

Solid Carbide Inserts	Part No.
Wedge for B=30	707.002.28
Wedge for B=50	707.002.48
Wedge for B=60	707.002.58
Wedge for B=80	707.002.78

# Stackable Insert Planing/Jointing Cutter

They can be used individually or pinned together to give a continuous planing edge from 20mm & up, depending on spindle length. An optional side tool can be supplied to carry out pre-straightening on the right side, allowing perfect positioning of work piece before the first vertical spindle on many moulders. Not recommended for finish cuts.

**4045**

D	B	d	Z	Part Number
80	50	Specify	4	4045.080.50
100	20	Specify	4	4045.100.20
100	30	Specify	4	4045.100.30
100	50	Specify	4	4045.100.50
125	20	Specify	4	4045.125.20
125	30	Specify	4	4045.125.30
125	50	Specify	4	4045.125.50



Solid Carbide Inserts	Part No.
30x12x1.5 for B=30	4200.030.00
50x12x1.5 for B=50	4200.050.00
60x12x1.5 for B=60	4200.060.00
M8x16 screw	705.542

Solid Carbide Inserts	Part No.
Wedge for B=30	707.002.28
Wedge for B=50	707.002.48
Wedge for B=60	707.002.58
Wedge for B=80	707.002.78

Recommended RPM:  
 D=100 7,800 - 13,300  
 D=125 6,200 - 10,600  
 D=80 9,600 - 16,000

# Insert Vari Angle Cutterhead

**GUHDO®**

Cutterhead body manufactured out of steel. Adjustable from 0° - 60°.  
Setting gauge available for precise adjustments in 2-1/2° increments.

**4056**

D	B	d	Z	Part Number
140	50	Specify	2	4056.140.50
170	50	Specify	2	4056.170.50
170	80	Specify	3	4056.170.53
Screw for wedge				705.555
Locking screw				705.341



# Insert Vari Angle Cutterhead

Cutterhead body manufactured from high quality light metal alloy.  
Adjustable from 0-90° in 2-1/2° increments.

**4058**

D	B	d	Part No.
160	50	Specify	4058.160.50
170	60	Specify	4058.170.60
200	80	Specify	4058.200.80
M6x10 screw			705.532
Locking screw			4058.200.80



Solid Carbide Inserts	Part No.
50 x 12 x 1.5 for B=50	4200.050.00
60 x 12 x 1.5 for B=60	4200.060.00
80 x 13 x 2.2 for B=80	4200.080.00
14 x 14 x 2.0 spur	4200.014.04
Setting gauge for no. 4056	726.101

Recommended RPM:  
 D=140 5,400 - 8,000  
 D=160 4,800 - 8,000  
 D=170 4,400 - 7,000  
 D=200 3,800 - 6,000

## Spiral Insert Planer Cutterhead

**4043**



Designed for planing solid material on a copy shaper, planer or moulder without lines. The helical design produces an aggressive cutting action and fast chip removal. The helical design also reduces noise and power consumption. Cutterhead body manufactured from high quality light metal alloy.

D	B	d	Z	Part Number
100	119	Specify	21	4043.100.18
100	173	Specify	30	4043.100.73
125	88	Specify	15	4043.125.88
125	119	Specify	21	4043.125.19
125	139	Specify	24	4043.125.39
125	156	Specify	27	4043.125.56
125	173	Specify	30	4043.125.73
125	218	Specify	39	4043.125.18
125	235	Specify	42	4043.125.35
4"	4"	1-1/4"	19	4043.102.12
4"	6"	1-1/4"	27	4043.102.15
140	4"	1-13/16"	19	4043.140.12
140	6"	1-13/16"	27	4043.140.15
140	9"	1-13/16"	42	4043.140.23



Solid Carbide Inserts	Part No.	Max RPM:
20 x 12 x 1.5	4200.021.20	D=100 13,300
M8x12 screw	705.541	D=125 11,000
		D=140 9,500
		D=4" 13,300

## Reference Insert Cutter Head

**4020**



Reference engraving cutter head to be used with series 4043 and 4811 planner heads.

No	D	B	d	Z	V	Part No.
1	145	12	Specify	3	3	4020.145.12
2	145	12	Specify	2	2	4020.146.12



Solid Carbide Inserts	Part No.
12 x 12 x 1.5	4200.012.00
14 x 14 x 2.0	4200.014.04

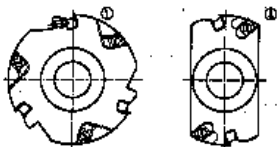

Spare Parts	Part No.	Spare Parts	Part No.
M8x16 screw	705.542	M5x8 screw (for spurs)	705.422
Wedge	707.002.10	Wrench SW4	706.104

# Insert Cutterhead For Tenons

**4044**

Special helical insert cutterhead designed for use on tenon machines. Cutterhead body manufactured from high quality light metal alloy with spurs on one side.



D	B	d	Z	V		Part No.
160	148	Specify	24	3	Top	4044.160.48
160	148	Specify	24	3	Bottom	4044.161.48

Solid Carbide Inserts	Part No.
20 x 12 x 1.5	4200.020.00
14 x 14 x 2.0	4200.014.04
M8x12 screw	705.541

Recommended RPM:  
4,800 - 8,500

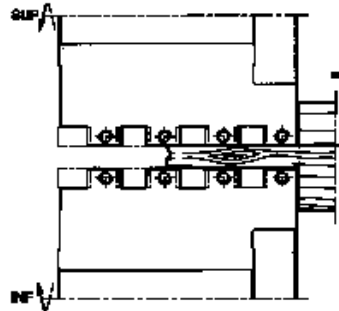

Cutters for Bacci, Balestrini, and Pade available upon request.

# V-Grooving Insert Cutterhead

**4071 Z2+2**

Designed for v-grooving and folding. Also suitable for producing rebates.



D	d	Z	Part No.
140	Specify	2+2	4071.140.35
200	Specify	2+2	4071.200.35

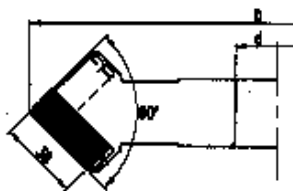

Solid Carbide Inserts	Part No.
30 x 12 x 1.5	6419.030.00
M8x12 screw	705.541

Recommended RPM:  
D=140 5,500 - 9,500  
D=200 3,900 - 6,600

# Insert Glue Joint Cutterhead

**GUHDO®**

For producing glue joint profiles in solid materials.

**4077**

D	B	d	Z	Wood Thickness	Profile No.	Part No.
140	50	Specify	2	20-45	1	4077.140.50
140	60	Specify	2	28-55	2	4077.140.60

Solid Carbide Inserts	Part No.
Carbide profile knife 50 mm	4200.092.50
Carbide profile knife 60 mm	4200.092.60
M8x16 screw	705.542

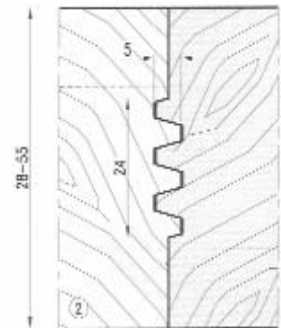
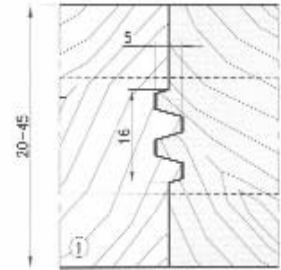

# Adjustable Glue Joint Cutter Head

Recommended RPM:  
4,800 - 8,300

Adjustable insert glue joint cutter  
for material thickness from 38 - 93 mm.

**4078**

D	B	d	Z	Part No.
160	100	Specify	3	4078.160.00

Solid Carbide Inserts	Part No.
50 x 25 x 2 No. 1	4078.050.00
50 x 25 x 2 No. 2	4078.050.01

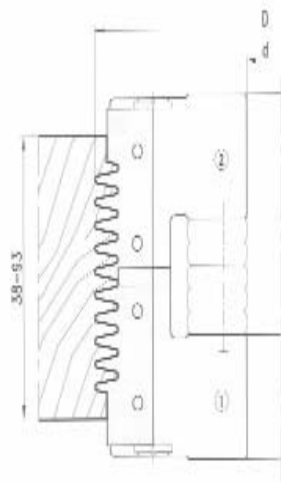

# Rounding/Joining Insert Cutterhead

**4073**

An adjustable insert cutterhead designed to joint, radius and chamfer the top and bottom edges of composites and solid woods. Available in different diameters for use on shapers and moulders.

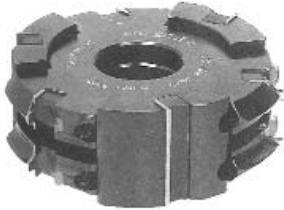

### Joining Cutterheads

Nr.	D	B	d	Z	R	Part No.
1	100	30	Specify	2		4073.100.30
1	100	50	Specify	2		4073.100.50
1	125	30	Specify	3		4073.125.30
1	125	50	Specify	3		4073.125.50

### Bottom Radius/Chamfer Cutterheads

Nr.	D	B	d	Z	R	Part No.
2	113	16	Specify	2	2-6	4073.113.00
2	137	16	Specify	3	2-6	4073.137.00
2	146	25	Specify	3	8-12	4073.146.00

### Top Radius/Chamfer Cutterheads

Nr.	D	B	d	Z	R	Part No.
2	113	16	Specify	2	2-6	4073.113.00
2	137	16	Specify	3	2-6	4073.137.00
2	146	25	Specify	3	8-12	4073.146.00

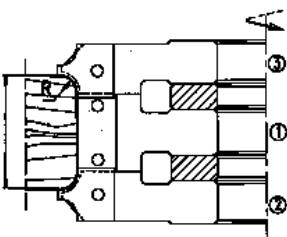
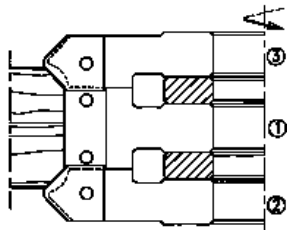

Solid Carbide Inserts	Part No.
30 x 12 x 1.5 for B=30	4200.030.00
50 x 12 x 1.5 for B=50	4200.050.00
16 x 17.5 x 1.5 R=2	4107.016.02
16 x 17.5 x 1.5 R=3	4107.016.03
16 x 17.5 x 1.5 R=4	4107.016.04
16 x 17.5 x 1.5 R=5	4107.016.05
16 x 17.5 x 1.5 R=6	4107.016.06
16 x 17.5 x 2 45°	4107.016.45
25 x 25 x 2 R=8	4107.025.08
25 x 25 x 2 R=10	4107.025.10
25 x 25 x 2 R=12	4107.025.12
20 x 21 x 2 45°	4107.020.45

#### Using 30mm Jointing Cutter

Radius	Min/Max wood thickness
2-6	12-39
8-12	20-47

#### Using 50mm Jointing Cutter

Radius	Min/Max wood thickness
2-6	16-60
8-12	20-67

# Rounding/Jointing Insert Cutterhead

**GUHDO®**

An adjustable insert cutterhead designed to joint, radius and chamfer the top and bottom edges of composites and solid woods. Adjustable material thickness from 12-50 mm.

D	B	d	Z	C	Part No.
125	50	Specify	4	4	4072.125.00

**4072**

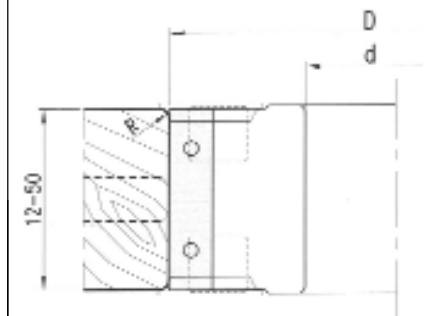
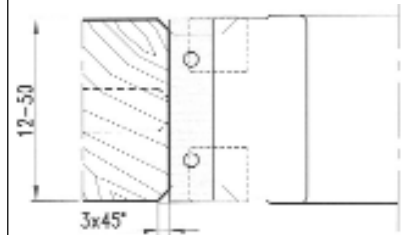

Recommended RPM:  
6,200 - 10,600

Solid Carbide Inserts

Part No.

50 x 12 x 1.5	4200.050.00
16 x 29 x 5 45	780.260
16 x 29 x 5 R=2	780.250
16 x 29 x 5 R=3	780.251

# Insert Mitre Joint Cutterhead

Recommended RPM:  
6,000 - 9,000

For producing self clamping mitre joints in  
composite and solid materials.  
For material thickness of 14 - 34 mm.

D	Wood thickness	d	Z	Part No.
180	14 - 34	Specify	2	4070.180.30

**4070**

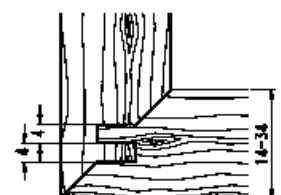
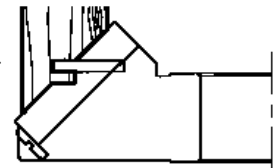

Solid Carbide Inserts

Part No.

Profile knife	4070.095.00
Grooving knife	4070.080.00
M8x16 screw	705.542
M5x13.5 for groove knife	705.318



## 4079

Profile A

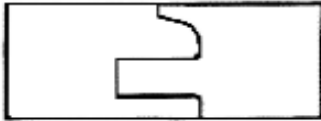

Profile B



Profile C

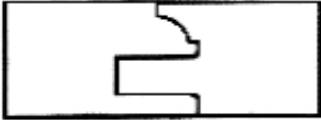

Dedicated insert cutter heads for producing cabinet doors. Consisting of one cutter for the stile and one cutter for the cope profiles. Each cutter is capable of producing the three profiles shown by simply changing the profile inserts. Profiles with radii for stain relief.

D	B	d	Z		Part No.
125	30	1-1/4	3	stile cutter	4079.125.00
125	30	1-1/4	3	cope cutter	4079.125.01

Total body price does not include profile inserts

Solid Carbide Inserts	Part No.
Stile profile A	4079.030.10
Cope profile A	4079.030.11
Stile profile B	4079.030.20
Cope profile B	4079.030.21
Stile profile C	4079.030.30
Cope profile C	4079.030.31

Recommended RPM:  
4,800 - 8,000

- for material thickness: 3/4" - 1"
- tongue depth: 1/2"
- groove width: 1/4"
- hook angle: 10°

Raise Panel Cutter Heads available upon request.

# Multi-Profile Insert Cutterhead

**GUHDO®**

A cutterhead that is designed to cut various profiles in solid woods and composite materials. Standard double sided inserts are used and supported by a steel backer plate. Profiles must fit within the specifications below.

**4080**



D	B	d	Z	Part Number
122	40	Specify	3	4080.122.40
128	60	Specify	3	4080.128.60
160	40	Specify	3	4080.160.40
160	60	Specify	3	4080.160.60
180	40	Specify	4	4080.180.40
180	60	Specify	4	4080.180.60
220	60	Specify	4	4080.220.61
220	60	Specify	6	4080.220.60

Solid Carbide Inserts (double-sided)	Part No.
40 x 30 x 2.0 (C4)	4202.040.30
60 x 35 x 2.0 (C4)	4202.060.35
C2 grade inserts available upon request	

Backer Plates	Part No.
40 x 30 x 4.0	4080.040.30
60 x 35 x 4.0	4080.060.35
Call for pricing on profile grinding	

**Recommended RPM:**

D=122	6,000 - 9,000
D=128	6,000 - 9,000
D=160	5,000 - 9,000
D=180	3,500 - 6,000
D=220	3,500 - 6,000

B=40 mm  
Max. Profile Depth: 11 mm  
Max. Profile Width: 32 mm

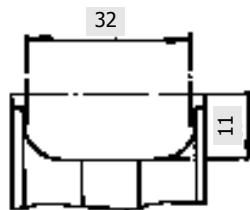

B=60 mm  
Max. Profile Depth: 14 mm  
Max. Profile Width: 52 mm

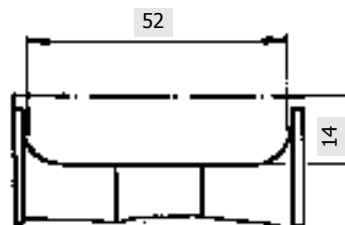

Raised panel cutter heads available upon request.

## Multi-Profile Insert Cutterhead

### 4081

A cutterhead that is designed to cut various deep profiles in solid woods and composite materials. Standard single sided inserts are used and supported by a steel backer plate. Profiles must fit within the specifications below.

D	B	d	Z	Part Number
160	40	Specify	3	4081.160.40
160	60	Specify	3	4081.160.60
180	60	Specify	4	4081.180.60
180	80	Specify	4	4081.180.80
220	60	Specify	4	4081.220.60
220	60	Specify	6	4081.220.61



Solid Carbide Inserts (single-sided)	Part No.
40 x 35 x 2.0 (C4)	4202.041.35
60 x 40 x 2.0 (C4)	4202.060.40
80 x 45 x 2.5 (C4)	4202.080.45
C2 grade inserts available upon request	

Backer Plates	Part No.
40 x 35 x 4.0	4080.040.35
60 x 40 x 4.0	4080.060.40
80 x 45 x 4.0	4080.080.45
Call for pricing on profile grinding	

Recommended RPM:	
D=160	5,000 - 9,000
D=180	4,200 - 8,000
D=220	3,500 - 6,000

B=40 mm  
Max. Profile Depth: 20 mm  
Max. Profile Width: 32 mm

B=60 mm  
Max. Profile Depth: 25 mm  
Max. Profile Width: 52 mm

B=80 mm  
Max. Profile Depth: 30 mm  
Max. Profile Width: 56 mm

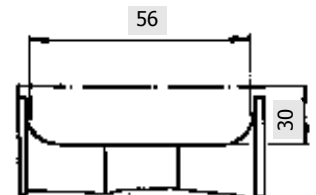
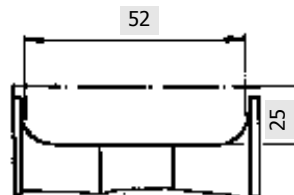
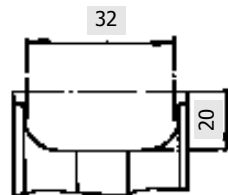

# Planer Cutterhead

**GUHDO®**

For use on shapers and moulders with mechanical feed. For planing solid material using 3mm thick HSS or TCT planer knives.

## 4811 Z4

D	B	d	Z	Part Number
125	80	Specify	4	4811.125.80
125	100	Specify	4	4811.125.10
125	130	Specify	4	4811.125.13
125	150	Specify	4	4811.125.15
125	180	Specify	4	4811.125.18
125	220	Specify	4	4811.125.22
125	230	Specify	4	4811.125.23
M10x20 screw				705.552



Maximum RPM:  
D=125 9,000

# Corrugated Moulder Cutterhead

For use on shapers and moulders with mechanical feed. Manufactured to accept 60° corrugated steel for planing and profiling. Available with 10°, 15° or 22° hook angles.

## 4894 Z4

D	B	d	Z	Part Number
122	40	Specify	4	4894.122.40
122	60	Specify	4	4894.122.60
122	80	Specify	4	4894.122.80
122	100	Specify	4	4894.122.10
122	130	Specify	4	4894.122.13
122	150	Specify	4	4894.122.15
122	180	Specify	4	4894.122.18
122	230	Specify	4	4894.122.23
137	40	Specify	4	4894.137.40
137	60	Specify	4	4894.137.60
137	80	Specify	4	4894.137.80
137	100	Specify	4	4894.137.10
137	130	Specify	4	4894.137.13
137	150	Specify	4	4894.137.15
137	180	Specify	4	4894.137.18
M12x20 screw				705.556

Also available with hydro sleeve.

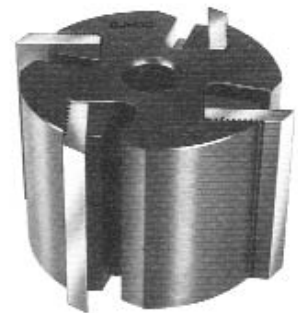

Maximum RPM:  
D=122 9,000  
D=137 9,000

**4200**

**6419**

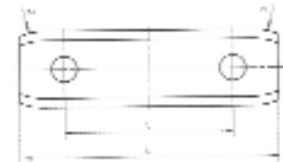
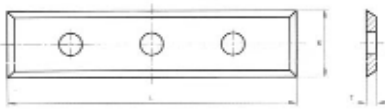
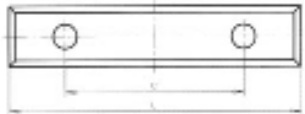
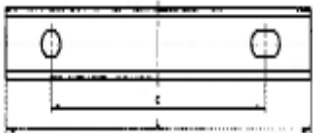
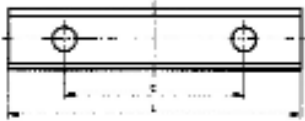
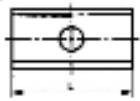

Dimension		Part No.
7.5 x 12 x 1.5		4200.008.00
9 x 12 x 1.5		4200.009.00
9.6 x 12 x 1.5		4200.096.00
10.5 x 12 x 1.5		4200.105.00
11 x 12 x 1.5		4200.011.00
13 x 12 x 1.5		4200.013.00
15 x 12 x 1.5		4200.015.00
17 x 12 x 1.5		4200.017.00
18 x 12 x 1.5		4200.018.00
19 x 12 x 1.5		4200.019.00
20 x 12 x 1.5		4200.020.00
25 x 12 x 1.5		4200.025.01
25 x 12 x 1.5		4200.025.00
30 x 12 x 1.5		4200.030.00
40 x 12 x 1.5		4200.040.00
50 x 12 x 1.5		4200.050.00
60 x 12 x 1.5		4200.060.00
80 x 13 x 2.2		4200.080.00
100 x 13 x 2.2		4200.100.00
120 x 13 x 2.2		4200.120.00
20 x 12 x 1.5	4 sided	6419.020.00
30 x 12 x 1.5	4 sided	6419.030.00
40 x 12 x 1.5	4 sided	6419.040.00
50 x 12 x 1.5	4 sided	6419.051.00
60 x 12 x 1.5	4 sided	6419.060.00
50 x 12 x 1.7	4 sided	6419.050.00
20 x 12 x 1.5	For Spiral Cutterheads	4200.021.20
30 x 12 x 1.5	For Spiral Cutterheads	4200.031.30
50 x 12 x 1.5	For Spiral Cutterheads	4200.051.50

**4200**

**4201**



Dimension		Part No.
6.7 x 8 x 1.5	for Leitz tools	4200.067.08
7.7 x 8 x 1.5	"	4200.077.08
9.7 x 8 x 1.5	"	4200.097.08
10.7 x 8 x 1.5	"	4200.107.08
11.7 x 8 x 1.5	for Leitz tools	4200.117.08
14.7 x 8 x 1.5	"	4200.147.08
15.7 x 8 x 1.5	"	4200.157.08
19.7 x 8 x 1.5	"	4200.197.08
24.7 x 8 x 1.5	for Leitz tools	4200.247.08
30 x 8 x 1.5	"	4200.030.08
35 x 8 x 1.5	"	4200.035.08
40 x 8 x 1.5	"	4200.040.08
50 x 8 x 1.5	for Leitz tools	4200.050.08
60 x 8 x 1.5	"	4200.060.08
80 x 8 x 1.5	"	4200.080.08
100 x 8 x 1.5	"	4200.100.08
120 x 8 x 1.5	"	4200.120.08
20 x 5.5 x 1.1	with back and cross groove, 4 sided	4201.020.11
30 x 5.5 x 1.1	with back and cross groove, 4 sided	4201.030.11
40 x 5.5 x 1.1	with back and cross groove, 4 sided	4201.040.11
50 x 5.5 x 1.1	with back and cross groove, 4 sided	4201.050.11
20 x 4.1 x 1.1	with back and cross groove, 4 sided	4201.021.11

# Solid Carbide Inserts

**GUHDO®**

Dimensions			Part No.
13 x 16 x 2	R=2	Leuco System	4106.013.02
13 x 16 x 2	R=3	Leuco System	4106.013.03
13 x 16 x 2	R=4	Leuco System	4106.013.04
20 x 21 x 2	R=5	Leuco System	4106.020.05
20 x 21 x 2	R=6	Leuco System	4106.020.06
20 x 21 x 2	R=7	Leuco System	4106.020.07
20 x 21 x 2	R=8	Leuco System	4106.020.08
26 x 24 x 2	R=9	Leuco System	4106.026.09
26 x 24 x 2	R=10	Leuco System	4106.026.10
26 x 24 x 2	R=11	Leuco System	4106.026.11
26 x 24 x 2	R=12	Leuco System	4106.026.12
26 x 24 x 2	R=13	Leuco System	4106.026.13

**4105**

**4106**

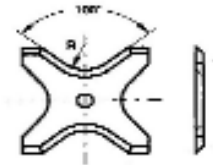

**4107**

**4108**

**4202**

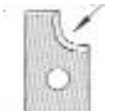
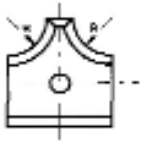

LH



RH

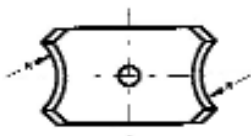

Dimensions			Part No.
16 x 17.5 x 2	R = 2	with 4.4 mm hole	4107.016.02
16 x 17.5 x 2	R = 3	with 4.4 mm hole	4107.016.03
16 x 17.5 x 2	R = 4	with 4.4 mm hole	4107.016.04
16 x 17.5 x 2	R = 5	with 4.4 mm hole	4107.016.05
16 x 17.5 x 2	R = 6	with 4.4 mm hole	4107.016.06
16 x 17.5 x 2	R = 2	with 3 mm hole	4202.016.02
16 x 17.5 x 2	R = 3	with 3 mm hole	4202.016.03
16 x 17.5 x 2	R = 4	with 3 mm hole	4202.016.04
16 x 17.5 x 2	R = 5	with 3 mm hole	4202.016.05
16 x 17.5 x 2	R = 6	with 3 mm hole	4202.016.06
12 x 12 x 1.5	R = 2	Holz-her System	4107.012.02
12 x 12 x 1.5	R = 3	Holz-her System	4107.012.03
12 x 12 x 1.5	R = 4	Holz-her System	4107.012.04
12 x 13 x 2	R = 3		4202.012.13
12 x 16 x 2	LH 15°	Leuco	4202.012.16
12 x 16 x 2	RH 15°	Leuco	4202.012.17
12 x 15 x 2	LH R = 2	Leuco	4202.012.02
12 x 15 x 2	RH R = 2	Leuco	4202.012.12
13 x 15 x 2	LH R = 3	Leuco	4202.013.14
13 x 15 x 2	RH R = 3	Leuco	4202.013.15
15 x 17 x 2	LH R = 5	Leuco	4202.015.17
15 x 17 x 2	RH R = 5	Leuco	4202.015.18
20 x 16 x 2	LH R = 3	Leuco	4202.020.16
20 x 16 x 2	RH R = 3	Leuco	4202.020.17
12 x 17 x 2	LH R = 3	Leuco	4202.012.18
12 x 17 x 2	RH R = 3	Leuco	4202.012.19
30 x 14 x 2	LH R = 3	Leuco	4202.030.15
30 x 14 x 2	RH R = 3	Leuco	4202.030.14
19.6 x 15.2 x 2	LH R = 3	Leuco	4202.196.15
19.6 x 15.2 x 2	RH R = 3	Leuco	4202.196.16
15 x 14.5 x 2	LH R = 3	Leuco	4202.015.14
15 x 14.5 x 2	RH R = 3	Leuco	4202.015.15
16.1 x 14 x 2	LH R = 3	Leuco	4202.161.15
16.1 x 14 x 2	RH R = 3	Leuco	4202.161.14
12 x 14.5 x 2	R = 3 RH		4202.012.14
12 x 14.5 x 2	R = 3 LH		4202.012.15
20 x 12 x 2	R = 2	Scrapper Knives	4108.020.02
20 x 12 x 2	R = 3	Scrapper Knives	4108.020.03
20 x 12 x 2	R = 4	Scrapper Knives	4108.020.04
20 x 12 x 2	R = 5	Scrapper Knives	4108.020.05



# Solid Carbide Inserts

**GUHDO®**

Dimension		Part No.
30 x 12 x 1.5	15 Degree LH	4200.030.30
30 x 12 x 1.5	15 Degree RH	4200.030.31
50 x 12 x 1.5	15 Degree LH	4200.050.30
50 x 12 x 1.5	15 Degree RH	4200.050.31
30 x 12 x 1.5	5 Degree LH for v-groove cutters	4200.030.20
30 x 12 x 1.5	5 Degree RH for v-groove cutters	4200.030.21
50 x 12 x 1.5	5 Degree LH for v-groove cutters	4200.050.20
50 x 12 x 1.5	5 Degree RH for v-groove cutters	4200.050.21
10.5 x 10.5 x 1.5	4 sided	4200.105.15
12 x 12 x 1.5	4 sided	4200.012.00
17 x 17 x 2.0	4 sided	4200.017.17
19 x 19 x 2.0	4 sided	4200.019.19
13 x 13 x 2.5	oppold-system	4200.013.25
13.6 x 13.6 x 2.0	4 sided	4200.013.13
14 x 14 x 1.2	4 sided	4200.014.12
14 x 14 x 1.2	Holz-Her scoring knives	4201.014.12
14 x 14 x 1.7	4 sided	4200.014.17
14 x 14 x 2.0	4 sided	4200.014.04
14.3 x 14.3 x 2.5	4 sided	4200.143.14
20 x 14.3 x 2.5	2 sided	4200.020.14
18 x 18 x 1.9		4200.018.20
18 x 18 x 2.45		4200.018.25
18 x 18 x 2.95		4200.018.30
18 x 18 x 3.7		4200.018.37
14 x 14 x 2.0	Howema System	4200.014.00
14 x 14 x 3.0	Howema System	4200.014.30
14.6 x 14.6 x 2.5		4200.146.25
15 x 15 x 2.0		4200.015.15
15 x 15 x 2.5		4200.015.25
15 x 15 x 2.5		4200.015.11
22 x 19 x 2.0	for Leitz Tools	4200.019.02
7.5 x 9 x 1.5		4200.008.09
9.6 x 9 x 1.5		4200.096.09
12 x 9 x 1.5		4200.012.09
12.6 x 9 x 1.5		4200.126.09
14.6 x 9 x 1.5		4200.146.09
20 x 9 x 1.5		4200.020.09
24 x 9 x 1.5		4200.024.09
26 x 9 x 1.5		4200.026.09
30 x 9 x 1.5		4200.030.09
40 x 9 x 1.5		4200.040.09
50 x 9 x 1.5		4200.050.09
60 x 9 x 1.5		4200.060.09
14 x 14 x 2.0		4200.014.14
16 x 7 x 1.5	single sided	6243.016.00
28 x 7 x 1.5	single sided	6243.028.00

## 4200

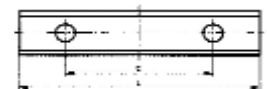
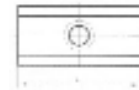
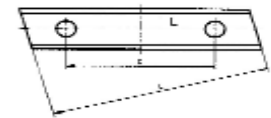
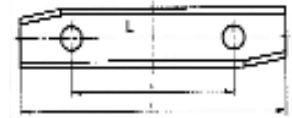

# Blank Inserts/Backer Plates



In addition to inserts and support plates for GUHDO multiprofile and dedicated insert cutterheads, we also offer a wide variety of inserts and backer plates for other manufacturers cutterheads.

Other inserts and backer plates available upon request.

C4 grade inserts supplied unless specified otherwise.

Dimensions			Part No.
<b>For GUHDO &amp; Stehle Systems-Inserts</b>			
40	30	2 double sided	4202.040.30
40	35	2 single sided	4202.041.35
60	35	2 double sided	4202.060.35
60	40	2 single sided	4202.060.40
<b>For GUHDO &amp; Stehle Systems-Brackers</b>			
40	30	4	4080.040.30
60	35	4	4080.060.35
60	40	4	4080.060.40
<b>For LEUCO System-Inserts</b>			
31	26	1.5 single sided	4202.031.26
41	28	1.5 single sided	4202.041.28
51	35	1.5 single sided	4202.051.35
61	31	1.5 single sided	4202.061.31
61	45	2 single sided	4202.061.45
81	45	2 single sided	4202.081.45
<b>For LEUCO System-Backers</b>			
41	28	4	4080.041.28
51	35	4	4080.051.35
61	31	4	4080.061.31
61	45	4	4080.061.45
81	45	4	4080.081.45
<b>For LEITZ System-Inserts</b>			
40	32.62	2 double sided	4202.040.32
40	42.86	2 double sided	4202.040.42
60	32.62	2 double sided	4202.060.32
60	42.86	2 double sided	4202.060.42

## Ball Bearing

**5000**

Ball bearing used in conjunction with the various guide rings shown below.



D	d	Part No.
69.85	1-1/4	5000.062.31

## Guide Rings

**5001**

For 5000



D	Part No.
80	5001.080.01
85	5001.085.01
90	5001.090.01
95	5001.095.01
100	5001.100.01
105	5001.105.01
110	5001.110.01
115	5001.115.01
120	5001.120.01
125	5001.125.01
130	5001.130.01
135	5001.135.01
140	5001.140.01

## Spacers

**5005**

Pricing upon request.



Diameter D=mm Bore d=mm	50 30NL	55 35NL	60 40NL	70 50NL	80 60NL
Thickness B=mm	0.1	0.2	0.3	0.4	0.5
	1	2	3	4	5
	6	8	10	12	14
	15	20			
NL=single keyway					

# Reducing Bushing With Flange

**GUHDO®**

Sizing and pricing upon request.

**5008**



# Reducing Sleeves

Sizing and pricing upon request.

**5010**

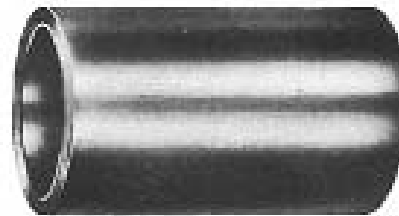

# Bushings For Saw Blades

2.2 mm thick

**5015**

D	d	Part No.
1"	5/8"	5015.001.58
20	16	5015.020.16
22	3/4"	5015.022.75
25	20	5015.025.20
30	5/8"	5015.030.58
30	16	5015.030.16
30	20	5015.030.20
30	24	5015.030.24
30	25	5015.030.25
30	1"	5015.030.01
32	16	5015.032.16
32	30	5015.032.30
35	30	5015.035.30
40	30	5015.040.30
40	35	5015.040.35

Special sizes available upon request

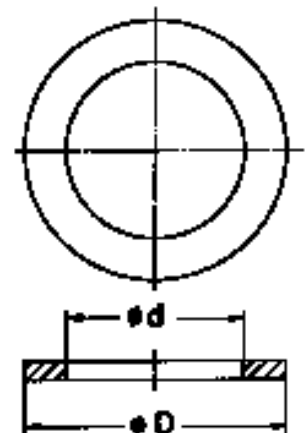

## Quick Change Adapter

### 6042/6043

For converting multi-spindle boring machines from using threaded boring bits to standard boring bits with 10 mm shanks. Consisting of two parts, the machine adapter and the drill holder offers quick and easy tool changes saving valuable production time. Ideal for high volume operations. Consult column for machine type.

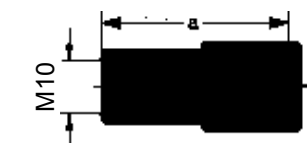
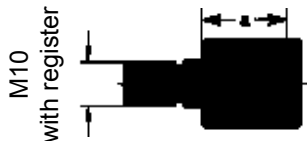
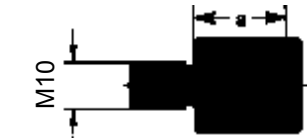
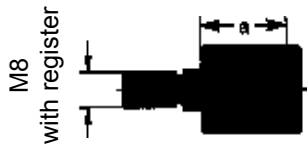
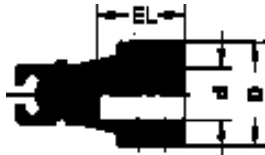

Quick change chucks that accept 8 mm shank drills available upon request.

Drill Holder	Part No. RH & LH
To fit in all machine adapters	6042.000.10

#### Machine adapters

For Machine	RH Part No.	LH Part No.
Nottmeyer (new), Brema	6043.010.10	6043.010.11
Ayen, Holzma Mayer, Torwegge	6043.002.10	6043.002.11
Maggi, Morbidelli, Weeke Torwegge, Biesse, Busellato Vitap (new), KOMO	6043.009.10	6043.009.11
Alberti, Bilek Balestrini, SCMI, Schleicher, Vitap (old)	6043.004.10	6043.004.11
Scheer	6043.100.10	6043.100.11

	Part No.
M5x4 replacement screw	39070-0-05040-R
Wrench for M5 screw	39120-0-02500-0
Wrench for machine adapter	39073-0-00800-0

# Threaded Adapter

**GUHDO®**  
**6050**

For converting multi-spindle boring machines from using threaded boring bits to standard boring bits with 10 mm shanks. Consult column for machine type.

For Machine	RH Part No.	LH Part No.
Nottmeyer (old),	6050.001.10	6050.001.11
Nottmeyer (new), Brema	6050.010.10	6050.010.11
Ayen, Holzma Mayer, Torwegge	6050.002.10	6050.002.11
Maggi, Morbidelli, Weeke, Torwegge, Biesse, Busellato, Vitap (new), KOMO	6050.009.10	6050.009.11
Bilek K&N	6050.005.10	6050.005.11
Alberti, Bilek, Balestrini, SCMI, Schleicher, Vitap (old)	6050.004.10	6050.004.11
Scheer	6050.100.10	6050.100.11

d	D2	D1	L1	Part No.	
For Weeke					
10	17.2	20	46	6050.006.10	
For Biesse & Koch					
10	-	20	37	RH	6050.003.10
10	-	20	37	LH	6050.003.11

	Part No.
M6x6 replacement screw	39070-0-06060-R

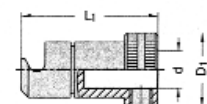
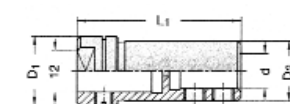
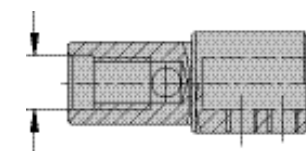

Threaded adapters that accept 8 mm shank drills available upon request.

## 6001

Solid tungsten carbide twist drill with parallel shank and "V" point.  
For use in drill holders 6002/6003 below.

HSS available upon request

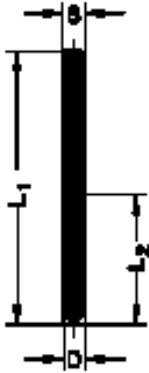

D	I	L	RH Part No.	LH Part No.
2	18	49	6001.020.00	6001.020.01
2,5	22	55	6001.025.00	6001.025.01
3	22	55	6001.030.00	6001.030.01
1/8	22	55	6001.032.00	6001.032.01
3,5	25	55	6001.035.00	6001.035.01
4	25	55	6001.040.00	6001.040.01

## Drill Holder

### 6002

Holder for twist drills No. 6001. Shank with flat for use in quick release adaptors 6040 and 6042 and reducing chucks 6050. Overall length is equivalent to dowel drills of 56/57mm length.

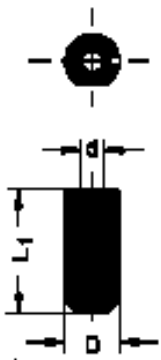

### 6002

### 6003

d	D	Split shank drill holder Part No.	Drill holder with shank Part No.
2	10	6002.020.00	6003.020.00
2,5		6002.025.00	6003.025.00
3		6002.030.00	6003.030.00
1/8		6002.032.00	6003.032.00
3,5		6002.035.00	6003.035.00
4		6002.040.00	6003.040.00
5		6002.050.00	
6		6002.060.00	

### 6003

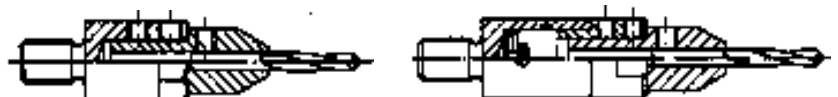
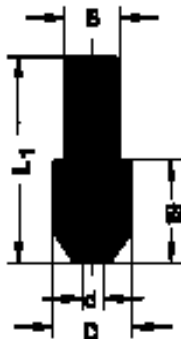

# TCT Hinge Boring Bit

**GUHDO®**

## 6016 Z2

D	L	S	Part No.
10	90	10 x 62	6016.100.00
11	90	10 x 62	6016.110.00
12	90	10 x 62	6016.120.00
13	90	10 x 62	6016.130.00
14	90	10 x 62	6016.140.00
15	90	10 x 62	6016.150.00
16	90	10 x 62	6016.160.00
17	90	10 x 62	6016.170.00
18	90	10 x 62	6016.180.00
19	90	10 x 62	6016.190.00
20	90	10 x 62	6016.200.00
21	90	10 x 62	6016.210.00
22	90	10 x 62	6016.220.00
23	90	10 x 62	6016.230.00
24	90	10 x 74	6016.240.00
25	90	10 x 74	6016.250.00
26	90	10 x 74	6016.260.00
27	90	10 x 74	6016.270.00
28	90	10 x 74	6016.280.00
29	90	10 x 74	6016.290.00
30	90	10 x 74	6016.300.00
31	90	10 x 74	6016.310.00
32	90	10 x 74	6016.320.00
33	90	10 x 74	6016.330.00
34	90	10 x 74	6016.340.00
35	90	10 x 74	6016.350.00
36	90	10 x 30	6016.360.00
37	90	10 x 30	6016.370.00
38	90	10 x 30	6016.380.00
39	90	10 x 30	6016.390.00
40	90	10 x 30	6016.400.00
41	90	10 x 30	6016.410.00
42	90	10 x 30	6016.420.00
43	90	10 x 30	6016.430.00
44	90	10 x 30	6016.440.00
45	90	10 x 30	6016.450.00
46	90	10 x 30	6016.460.00
47	90	10 x 30	6016.470.00
48	90	10 x 30	6016.480.00
49	90	10 x 30	6016.490.00
50	90	10 x 30	6016.500.00
51	90	10 x 30	6016.510.00
52	90	10 x 30	6016.520.00
53	90	10 x 30	6016.530.00
54	90	10 x 30	6016.540.00
55	90	10 x 30	6016.550.00
56	90	10 x 30	6016.560.00
57	90	10 x 30	6016.570.00
58	90	10 x 30	6016.580.00
59	90	10 x 30	6016.590.00
60	90	10 x 30	6016.600.00

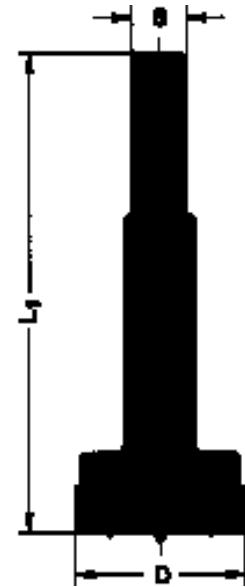



## Insert Hinge Boring Bit

### 6095 Z2



D	L	S	RH Part No.	LH Part No.
25	57	10 x 26	6095.250.00	6095.250.01
26	57	10 x 26	6095.260.00	6095.260.01
30	57	10 x 26	6095.300.00	6095.300.01
35	57	10 x 26	6095.350.00	6095.350.01

Solid Carbide Inserts	Part No.
For D = 25	4200.105.00
For D = 26	4200.011.00
For D = 30	4200.013.00

Solid Carbide Inserts	Part No.
For D = 35	4200.015.00
Spur	6095.000.50
Center Point	6095.000.60

### 6096

New style insert boring bit with interchangeable shanks to obtain an overall tool length of 55.5, 70, 90 and 140 mm length.

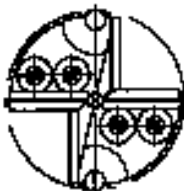
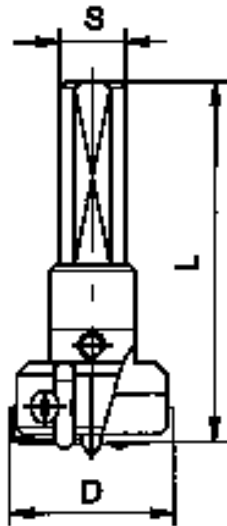

D	L	S	RH Part No.	LH Part No.
25	55.5	10x28	6096.250.00	6096.250.01
26	55.5	10x28	6096.260.00	6096.260.01
30	55.5	10x28	6096.300.00	6096.300.01
34	55.5	10x28	6096.340.00	-
35	55.5	10x28	6096.350.00	6096.350.01
40	55.5	10x28	6096.400.00	6096.400.01
25	70	10x28	6096.250.10	6096.250.11
26	70	10x28	6096.260.10	6096.260.11
30	70	10x28	6096.300.10	6096.300.11
35	70	10x28	6096.350.10	6096.350.11
40	70	10x28	6096.400.10	6096.400.11

#### Interchangeable Shanks

10x28 mm for 57 mm length	6069.000.55	6096.000.56
10x28 mm for 70 mm length	6069.000.70	6096.000.71
10x30 mm for 90 mm length	6096.000.90	-
13x50 mm for 140 mm length	6096.000.14	-

Solid Carbide Inserts	Part No.
10.8x5.5x1.1 for D=25mm	6096.108.00
11.3x5.5x1.1 for D=26mm	6096.113.00
13.3x5.5x1.1 for D=30mm	6096.133.00
15.3x5.5x1.1 for D=34mm	6096.153.00
15.8x5.5x1.1 for D=35mm	6096.158.00
18.3x5.5x1.1 for D=40mm	6096.183.00
Spur RH	6096.000.00
Spur LH	6096.000.01
Center Point	6096.000.50

Replacement Parts	Part No.
Retaining Ring	39110-0-00001-0
Screw for inserts	39115-0-00001-0
Screw for spur	39084-0-03070-R
Screw for center point	39080-0-30701-R
Torx wrench (T8)	39077-0-03008-1

# TCT Hinge Boring Bit

**GUHDO®**

With center point and shank adjustment screw.

## 6017 Z2

D	L	S	RH Part No.	LH Part No.
15	57	10 x 26	6017.150.00	6017.150.01
16	57	10 x 26	6017.160.00	6017.160.01
16.5	57	10 x 26	6017.165.00	
18	57	10 x 26	6017.180.00	6017.180.01
19	57	10 x 26	6017.190.00	6017.190.01
20	57	10 x 26	6017.200.00	6017.200.01
22	57	10 x 26	6017.220.00	6017.220.01
24	57	10 x 26	6017.240.00	6017.240.01
25	57	10 x 26	6017.250.00	6017.250.01
26	57	10 x 26	6017.260.00	6017.260.01
28	57	10 x 26	6017.280.00	6017.280.01
30	57	10 x 26	6017.300.00	6017.300.01
32	57	10 x 26	6017.320.00	6017.320.01
35	57	10 x 26	6017.350.00	6017.350.01
38	57	10 x 26	6017.380.00	6017.380.01
40	57	10 x 26	6017.400.00	6017.400.01
15	70	10 x 26	6017.150.10	6017.150.11
18	70	10 x 26	6017.180.10	6017.180.11
20	70	10 x 26	6017.200.10	6017.200.11
25	70	10 x 26	6017.250.10	6017.250.11
26	70	10 x 26	6017.260.10	6017.260.11
30	70	10 x 26	6017.300.10	6017.300.11
35	70	10 x 26	6017.350.10	6017.350.11
40	70	10 x 26	6017.400.10	6017.400.11
20	77	10 x 26	6017.200.40	6017.200.41
25	77	10 x 26	6017.250.40	6017.250.41
30	77	10 x 26	6017.300.40	6017.300.41
35	77	10 x 26	6017.350.40	6017.350.41

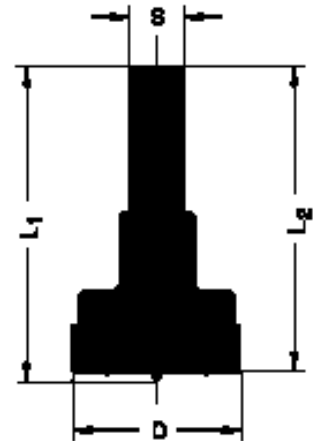

With shank adjustment screw and two center point options,  
with center point or without center point.

## 6018 Z3

D	L	S	RH Part No.	LH Part No.
With center point				
25	57	10 x 26	6018.250.00	6018.250.01
26	57	10 x 26	6018.260.00	6018.260.01
30	57	10 x 26	6018.300.00	6018.300.01
35	57	10 x 26	6018.350.00	6018.350.01
Without center point				
25	57	10 x 26	6018.250.02	6018.250.03
26	57	10 x 26	6018.260.02	6018.260.03
30	57	10 x 26	6018.300.02	6018.300.03
35	57	10 x 26	6018.350.02	6018.350.03

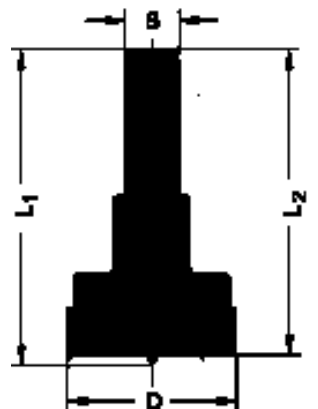

## TCT Dowel Drill

### 6019

With brad point and shank adjustment screw.

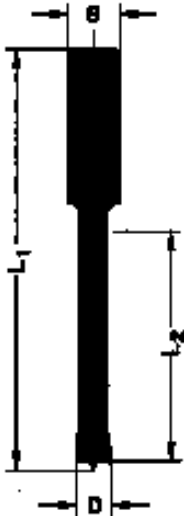

D	I	L	S	RH Part No.	LH Part No.
5	45	85	10 x 30	6019.050.00	6019.050.01
6	45	85	10 x 30	6019.060.00	6019.060.01
7	45	85	10 x 30	6019.070.00	6019.070.01
8	45	85	10 x 30	6019.080.00	6019.080.01
10	45	85	10 x 30	6019.100.00	6019.100.01
12	45	85	10 x 30	6019.120.00	6019.120.01
5	65	105	10 x 30	6019.050.10	6019.050.11
6	65	105	10 x 30	6019.060.10	6019.060.11
7	65	105	10 x 30	6019.070.10	6019.070.11
8	65	105	10 x 30	6019.080.10	6019.080.11
10	65	105	10 x 30	6019.100.10	6019.100.11
12	65	105	10 x 30	6019.120.10	6019.120.11

## TCT V-Point Drill

### 6028

V-Point for eliminating blow out when drilling through double sided material.

With shank adjustment screw.

Selected sizes also available with 8 mm shanks.

Special diameters available upon request.

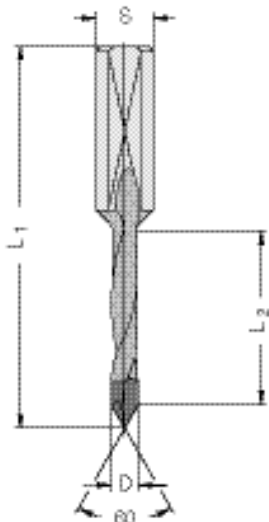

D	I	L	S	RH Part No.	LH Part No.
3	27	57	10 x 22	6028.030.20	6028.030.21
4	25	57	10 x 25	6028.040.20	6028.040.21
5	27	57	10 x 24	6028.050.20	6028.050.21
5.1	27	57	10 x 24	6028.051.20	6028.051.21
6	27	57	10 x 24	6028.060.20	6028.060.21
8	27	57	10 x 24	6028.080.20	6028.080.21
10	27	57	10 x 24	6028.100.20	6028.100.21
4	35	70	10 x 24	6028.040.30	6028.040.31
5	35	70	10 x 24	6028.050.30	6028.050.31
6	35	70	10 x 24	6028.060.30	6028.060.31
1/4	35	70	10 x 24	6028.635.30	6028.635.31
7	35	70	10 x 24	6028.070.30	6028.070.31
8	35	70	10 x 24	6028.080.30	6028.080.31
9	35	70	10 x 24	6028.090.30	6028.090.31
3/8	35	70	10 x 24	6028.953.30	6028.953.31
10	35	70	10 x 24	6028.100.30	6028.100.31
12	35	70	10 x 24	6028.120.30	6028.120.31
5	45	77	10 x 24	6028.050.40	6028.050.41
6	45	77	10 x 24	6028.060.40	6028.060.41
8	45	77	10 x 24	6028.080.40	6028.080.41
10	45	77	10 x 24	6028.100.40	6028.100.41
12	45	77	10 x 24	6028.120.40	6028.120.41

# TCT Dowel Drill

# GUHDO®

With brad point and shank adjustment screw.

## 6024

D	I	L	S	RH Part No.	LH Part No.
3	16	57	10 x 30	6024.030.00	6024.030.01
4	27	57	10 x 30	6024.040.00	6024.040.01
4.5	27	57	10 x 30	6024.045.00	6024.045.01
5	27	57	10 x 30	6024.050.00	6024.050.01
5.1	27	57	10 x 30	6024.051.00	6024.051.01
5.2	27	57	10 x 30	6024.052.00	6024.052.01
6	27	57	10 x 30	6024.060.00	6024.060.01
1/4"	27	57	10 x 30	6024.635.00	6024.635.01
7	27	57	10 x 30	6024.070.00	6024.070.01
8	27	57	10 x 30	6024.080.00	6024.080.01
8.2	27	57	10 x 30	6024.082.00	6024.082.01
9	27	57	10 x 30	6024.090.00	6024.090.01
3/8"	27	57	10 x 30	6024.953.00	6024.953.01
10	27	57	10 x 30	6024.100.00	6024.100.01
11	27	57	10 x 30	6024.110.00	6024.110.01
12	27	57	10 x 30	6024.120.00	6024.120.01
1/2"	27	57	10 x 30	6024.127.00	6024.127.01
13	30	57	10 x 20	6024.130.00	6024.130.01
14	30	57	10 x 20	6024.140.00	6024.140.01
15	30	57	10 x 20	6024.150.00	6024.150.01
16	30	57	10 x 20	6024.160.00	6024.160.01
4	35	70	10 x 30	6024.040.10	6024.040.11
5	35	70	10 x 30	6024.050.10	6024.050.11
7/32	35	70	10 x 30	6024.555.10	6024.555.11
6	35	70	10 x 30	6024.060.10	6024.060.11
1/4"	35	70	10 x 30	6024.635.10	6024.635.11
7	35	70	10 x 30	6024.070.10	6024.070.11
8	35	70	10 x 30	6024.080.10	6024.080.11
9	35	70	10 x 30	6024.090.10	6024.090.11
3/8"	35	70	10 x 30	6024.953.10	6024.953.11
10	35	70	10 x 30	6024.100.10	6024.100.11
11	35	70	10 x 30	6024.110.10	6024.110.11
12	35	70	10 x 30	6024.120.10	6024.120.11
1/2"	35	70	10 x 30	6024.127.10	6024.127.11
13	43	70	10 x 20	6024.130.10	6024.130.11
14	43	70	10 x 20	6024.140.10	6024.140.11
15	43	70	10 x 20	6024.150.10	6024.150.11
16	43	70	10 x 20	6024.160.10	6024.160.11
5	44	77	10 x 30	6024.050.40	6024.050.41
6	44	77	10 x 30	6024.060.40	6024.060.41
7	44	77	10 x 30	6024.070.40	6024.070.41
8	44	77	10 x 30	6024.080.40	6024.080.41
10	44	77	10 x 30	6024.100.40	6024.100.41
12	44	77	10 x 30	6024.120.40	6024.120.41



Selected sizes also available with 8 mm shanks.

Special diameters available upon request.

## Solid Carbide Boring Bit

### 6021

New style solid carbide boring bit with special carbide grade. With large gullet to improve chip flow, extend tool life and increase boring rates. **Can be used for either RH or LH rotation.** Ideal for point to point machines.

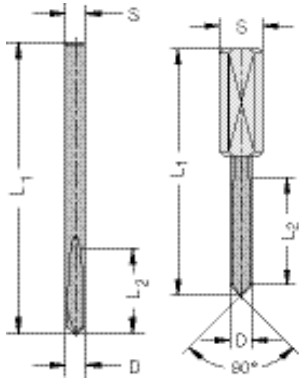

D	L2	L1	S	Part Number
3	12	45	3	6021.030.00
4	12	45	4	6021.040.00
5	25	57	10 x 25	6021.050.00
6	25	57	10 x 25	6021.060.00
8	25	57	10 x 25	6021.080.00
5	35	70	10 x 25	6021.050.10
6	35	70	10 x 25	6021.060.10
8	35	70	10 x 25	6021.080.10

3 and 4 mm drills require 6003 adapter

Feed per revolution:

n =	3000	4500	6000	9000	12000 min
s max =	1.0	1.0	0.8	0.6	0.5 mm

## TCT Dowel Drill

### 6023

New style brad point boring bit with 10mm shank. With larger gullets to improve chip flow and extend tool life. The smaller tool body (see below), also increases the boring speed.

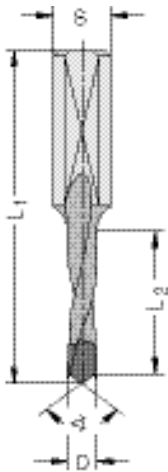

D	I	L	S	RH Part No.	LH Part No.
5	27	57	10 x 27	6023.050.00	6023.050.01
6	27	57	10 x 27	6023.060.00	6023.060.01
8	27	57	10 x 27	6023.080.00	6023.080.01
10	27	57	10 x 27	6023.100.00	6023.100.01
5	35	70	10 x 30	6023.050.10	6023.050.11
6	35	70	10 x 30	6023.060.10	6023.060.11
8	35	70	10 x 30	6023.080.10	6023.080.11
10	35	70	10 x 30	6023.100.10	6023.100.11

Recommended Feedrate:

n (min <sup>-1</sup> )	v <sub>r</sub> (m min <sup>-1</sup> )
3000	1 - 2
4500	1.5 - 2.5
6000	2 - 3.5
9000	2.5 - 5.5

Depending on material, the optimum feedrate must be determined within the range provided.



# Long Life Dowel Drill

**GUHDO®**

New style brad point bit with 10mm shank. With larger gullets to improve chip flow and increase boring speed. Supplied with TeFlon coating and a special carbide grade for superior run times over traditional carbide boring bits.

## 6025

D	I	L	S	RH Part No.	LH Part No.
4	27	57.5	10x27	6025.040.00	6025.040.01
5	27	57.5	10x27	6025.050.00	6025.050.01
6	27	57.5	10x27	6025.060.00	6025.060.01
8	27	57.5	10x27	6025.080.00	6025.080.01
10	27	57.5	10x27	6025.100.00	6025.100.01
4	35	70	10x30	6025.040.10	6025.040.11
5	35	70	10x30	6025.050.10	6025.050.11
6	35	70	10x30	6025.060.10	6025.060.11
8	35	70	10x30	6025.080.10	6025.080.11
10	35	70	10x30	6025.100.10	6025.100.11

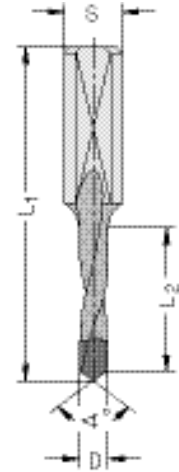

# Long Life V-Point Drill

New style brad point bit with 10mm shank. With larger gullets to improve chip flow and increase boring speed. Supplied with TeFlon coating and a special carbide grade for superior run times over traditional carbide boring bits.

## 6128

D	I	L	S	RH Part No.	LH Part No.
5	27	57.5	10x27	6128.050.20	6128.050.21
5	35	70	10x30	6128.050.30	6128.050.31
8	35	70	10x30	6128.080.30	6128.080.31

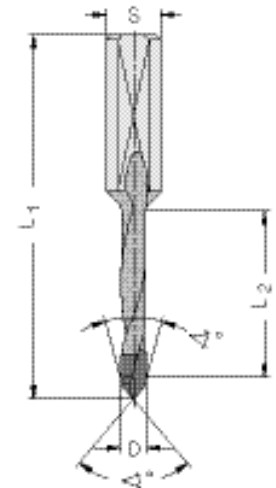

# TCT Dowel Drill With Threaded Shank

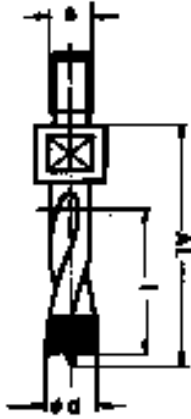

No. 6061 & 6062 series

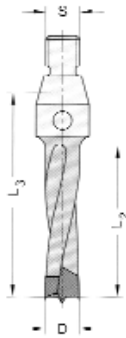

No. 6064 series

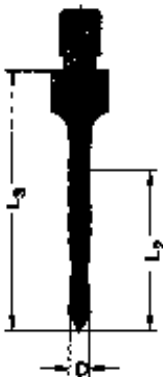

No. 6070 series

Dowel drills with M10 internal shank for Sheer machines available upon request.

## 6061

With brad point and M8 threaded shank for Morbidelli and Nottmeyer machines.

D	I	L	RH Part No.	LH Part No.
5	45	63	6061.050.00	6061.050.01
6	45	63	6061.060.00	6061.060.01
8	45	63	6061.080.00	6061.080.01
10	45	63	6061.100.00	6061.100.01
12	45	63	6061.120.00	6061.120.01

## 6062

With brad point and M10 threaded shank for Ayen, Biesse, Busellato, Morbidelli and Weeke machines.

D	I	L	RH Part No.	LH Part No.
5	45	63	6062.050.00	6062.050.01
6	45	63	6062.060.00	6062.060.01
8	45	63	6062.080.00	6062.080.01
10	45	63	6062.100.00	6062.100.01
12	45	63	6062.120.00	6062.120.01

## 6064

With brad point and M10/30° threaded shank for Alberti, SCMI, Schleicher and Vitap machines.

D	I	L	RH Part No.	LH Part No.
5	45	61	6064.050.00	6064.050.01
6	45	61	6064.060.00	6064.060.01
8	45	61	6064.080.00	6064.080.01
10	45	61	6064.100.00	6064.100.01
12	45	61	6064.120.00	6064.120.01

## 6070

With V-point and M10 threaded shank for Ayen, Biesse, Busellato, Morbidelli and Weeke machines.

D	I	L	RH Part No.	LH Part No.
5	30	50	6070.050.30	6070.050.31
5	40	65	6070.050.40	6070.050.41
5.1	40	65	6070.051.40	6070.051.41

# TCT Countersink

**GUHDO®**

For use with dowel and V-point drills. Clamping on the spiral.

## 6030 Z2

d	D	RH Part No.	LH Part No.
4	15.5	6030.040.00	6030.040.01
5	15.5	6030.050.00	6030.050.01
6	15.5	6030.060.00	6030.060.01
1/4"	15.5	6030.635.00	6030.635.01
7	18	6030.070.00	6030.070.01
8	18	6030.080.00	6030.080.01
9	18	6030.090.00	6030.090.01
10	20	6030.100.00	6030.100.01
12	20	6030.120.00	6030.120.01

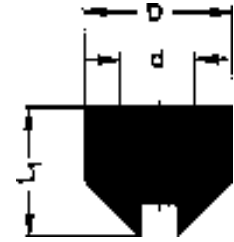

For use with dowel and V-point drills. Clamping on the shank.

## 6034 Z2

d	D	For Drills	RH Part No.	LH Part No.
10	20	5 to 10	6034.010.00	6034.010.01
10	22	11 and 12	6034.020.00	6034.020.01

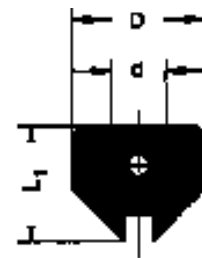

# Special HSS & TCT Drills

No. 6012 and 6112 are specially manufactured drills with built in countersinks or counterbores. For quoting purposes, please specify quantity, material (HSS or TCT), brad or V-Point, rotation and all dimensions per the drawing shown.

## 6012/6112

Form A

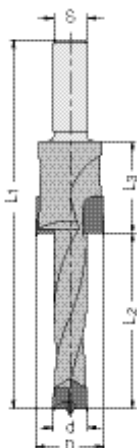

Form B

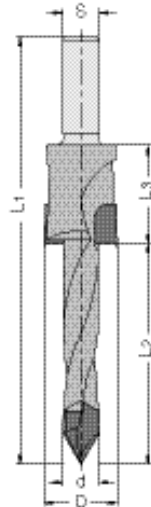

Form C

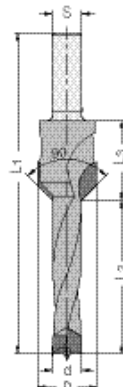

Form D

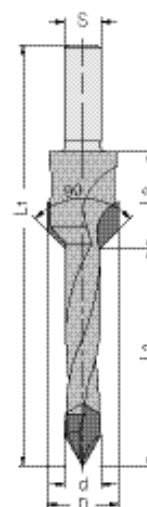



**6107**

Slot mortise or Louver bits for producing a mortise in soft woods.  
Manufactured out of high quality tool steel.

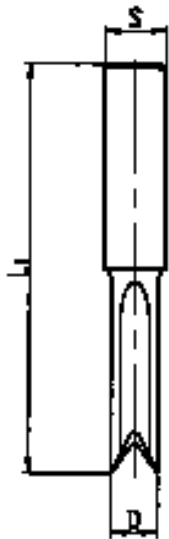

D	L	S	Z	Part Number
6	73	10	4	6107.060.10
1/4	73	10	4	6107.635.10
7	73	10	4	6107.070.10
8	73	10	4	6107.080.10
3/8	73	10	4	6107.953.10
10	73	10	4	6107.100.10
12	73	10	4	6107.120.10
1/2	73	10	4	6107.127.10

- above with flat on shanks

6	60	12	4	6107.060.12
7	60	12	4	6107.070.12
8	60	12	4	6107.080.12
10	60	12	4	6107.100.12
12	60	12	4	6107.120.12

6	100	13	4	6107.060.13
7	100	13	4	6107.070.13
8	100	13	4	6107.080.13
9	100	13	4	6107.090.13
10	110	13	4	6107.100.13
12	110	13	4	6107.120.13
14	110	13	4	6107.140.13
16	110	13	4	6107.160.13

6	100	16	2	6107.060.16
7	100	16	2	6107.070.16
8	100	16	2	6107.080.16
9	100	16	2	6107.090.16
10	110	16	2	6107.100.16
12	110	16	2	6107.120.16
14	110	16	2	6107.140.16
16	110	16	2	6107.160.16

# Insert Trimming Router Bit

**GUHDO®**

For trimming edges of veneered or plastic coated panels without a bearing.

## 7915 Z2

D	L2	0°	S	Part Number
20	12	0	1/4	7915.020.00
22	12	0	1/4	7915.022.00
27	12	15	1/4	7915.027.15
30	12	30	1/4	7915.030.30
29	12	45	1/4	7915.029.45

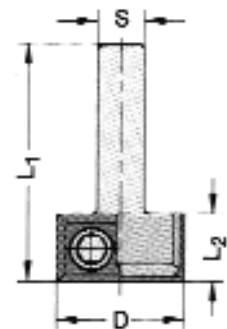

Solid carbide inserts	Part No.
12 x 12 x 1.5	4200.012.00

For trimming edges of veneered or plastic coated panels with a bearing.

## 7920/7930 Z2

D	L2	0°	S	Part Number
22	12	0	1/4	7920.220.00
22	20	0	1/4	7920.221.00
24	12	15	1/4	7930.024.15
28	12	22	1/4	7930.028.22
30	12	30	1/4	7930.030.30
32	12	45	1/4	7930.032.45

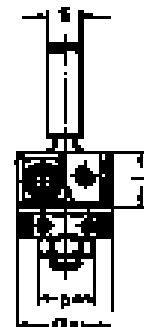

Solid carbide inserts	Part No.
12 x 12 x 1.5 for L2=12	4200.012.00
20 x 12 x 1.5 for L2=20	4200.020.00
Replacement bearing (call for part no. and pricing)	

# Insert Trimming Router Bit

## 7925 Z2

For trimming edges of veneered or plastic coated panels with a bearing.

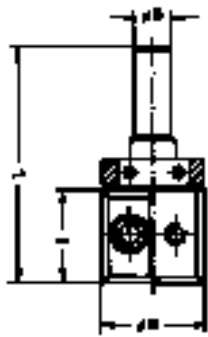

D	L2	S	Part No.
22	20	1/4	7925.220.63
22	20	1/2	7925.220.12
22	30	1/4	7925.221.63
22	30	1/2	7925.221.12
22	50	1/4	7925.222.63
22	50	1/2	7925.222.12

Solid carbide inserts	Part No.
20 x 12 x 1.5 for L2=20	4200.020.00
30 x 12 x 1.5 for L2=30	4200.030.00
50 x 12 x 1.7 for L2=50	6419.050.00
Replacement bearing (call for part no. and pricing)	

## Special Insert Tooling

GUHDO also offers a full program of special cutters and cuttersets for the production of windows and doors. We offer cuttersets mounted on individual sleeves or multiple cutterset designed for machines equipped with stacked spindles. Complete machine specification, material information and detailed drawings are necessary for pricing.



# Recommended Cutting Angles & Finish



	Kiln Dried 7% Moisture or Less	Wet or Green More than 7%	Knife Marks Per Inch
Ash	15°	10°	11 - 14
Basswood	10°	20°	8 - 12
Beech	10°	15°	12 - 14
Birch	10°	15°	13 - 16
Cedar	5°	10°	8 - 12
Cherry	10°	15°	12 - 14
Chestnut	5°	10°	
Cottonwood	5°	10°	8 - 12
Cypress	5°	10°	8 - 12
Elm Hard	0°	5°	10 - 13
Fir	10°	15°	8 - 12
Gum	20°	25°	9 - 12
Hemlock	15°	20°	8 - 12
Hickory	5°	10°	12 - 15
Mahogany	10°	15°	12 - 14
Maple	5°	10	12 - 14
Oak	10°	15°	12 - 14
Yellow Pine	20°	25°	9 - 13
White Pine	25°	30°	
Pondersosa Pine	25°	30°	
Poplar	30°	35°	9 - 13
Redwood	5°	10°	8 - 12
Spruce	20°	25°	8 - 12
Sycamore	5°	10°	11 - 14
Walnut	5°	10°	12 - 14
Soft Elm	5°	10°	8 - 12

# Our Guarantee

GUHDO Tools are guaranteed against defects in workmanship, materials and performance provided the tool has not been incorrectly applied or misused.

## For Your Information

### Shipping Procedures

All shipments are shipped by UPS unless otherwise specified.

### Returning Merchandise

- Merchandise may be returned only with advanced approval.
- There will be a 15% restocking charge on returned stock items.
- Non stock items will have a 20% restocking charge.
- Custom tooling is not returnable, neither are discontinued items.
- No merchandise may be returned after 6 months from the date of purchase.  
Shipping charges on all returned merchandise must be prepaid.

### Cancellation

- On standard orders, cancellation will be accepted without charge. Special orders may be cancelled, but there will be a charge that is reasonable and proper, based on the status of merchandise in process and expenses already incurred as well as commitments made by the company.

### Terms

- All new accounts will be shipped on a C.O.D. or Credit Card basis until credit has been established. Credit Accounts are due 30 days from the date of invoice. Past due accounts will be charged a finance charge at the periodic rate of 1½% per month, which is an Annual Percentage Rate of 18%. A minimum finance charge of \$1.00 will be charged on past due accounts. All prices are FOB Marietta, Georgia. All collection costs will be the expense of the customer.

**Title To Merchandise Purchased By Customer Shall Be Retained By  
GUHDO USA INC.  
Until Paid In Full.**

All prices and specifications are subject to change without notice.